

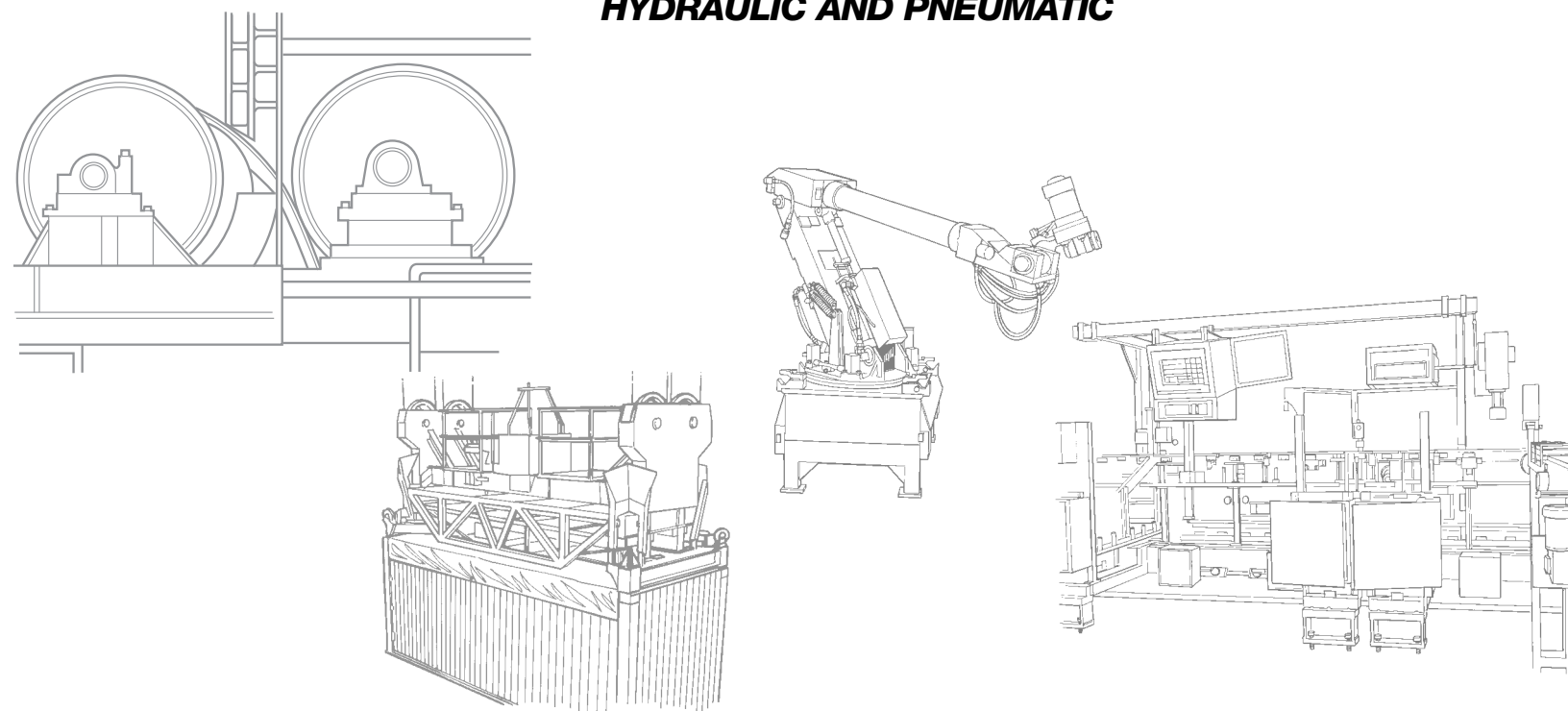

Rotary Actuators

HYDRAULIC AND PNEUMATIC





Micromatic

Welcome

TO MICROMATIC

Welcome to the world of rotary motion. We appreciate your interest and are pleased to offer you our catalog, featuring Micromatic's extensive line of rotary actuators. Micromatic actuators have earned worldwide renown under the trade names of Rotac[®] and Hyd-ro-ac[™]. Micromatic, long recognized as an industry leader, has been designing and manufacturing rotary actuators for over forty years.

Micromatic provides actuators with either hydraulic or pneumatic capability. Your imagination alone limits the number of possible applications.

We offer true "A to Z" capability. Our standard units produce up to 700,000 in. lbs. of torque @ 3000 PSI, and we have designed "specials" with 4,500,000 in. lbs. @ 2200 PSI capability.

If your application requires an actuator outside the range of our standard line, our seasoned product design and application engineering group will modify and/or design a specialty actuator to suit your needs.

Give your Micromatic distributor a call, and let our sales team help you make your equipment the very best possible.

CONTENTS

<u>Applications</u>	<u>2-5</u>
<u>Engineering Data</u>	<u>6-25</u>
<u>Flow Rate Data</u>	<u>19-21</u>
<u>Guide To Size</u>	<u>22-25</u>
<u>LP Models</u> <small>up to 150 psi, pneumatic</small>	<u>27-30</u>
<u>MP Models</u> <small>up to 1,000 psi, medium pressure</small>	<u>31-34</u>
<u>26R Models</u> <small>up to 3,000 psi, high pressure</small>	<u>35-38</u>
<u>SS Models</u> <small>up to 3,000 psi, high pressure, solid shaft</small>	<u>39-42</u>
<u>HS Models</u> <small>up to 3,000 psi, high pressure, hollow shaft</small>	<u>43-46</u>
<u>Rotating Actuators</u>	<u>47-50</u>
<u>Options and Accessories</u>	<u>51-56</u>

Applications

1 **Product:** Back Hoes
Actuator Used: SS Series
Application: Back Hoe Swing

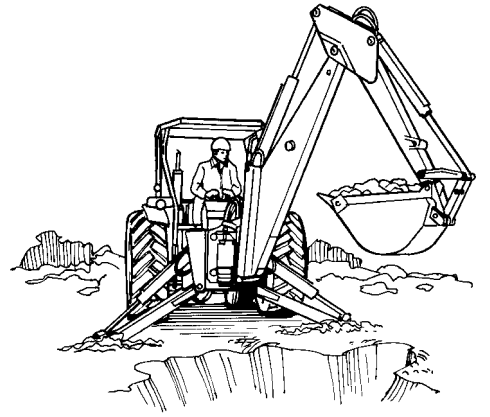

1

2 **Product:** Boat Launch
Actuator Used: HS Series
Application: Davit Swing

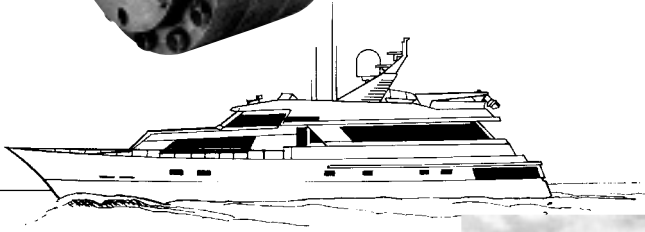

2

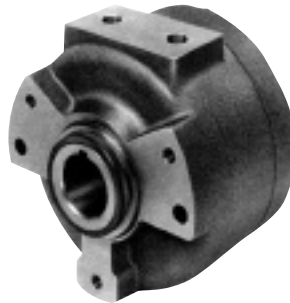

3

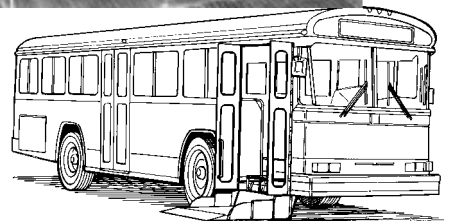

Applications

4 **Product:** Log Loaders
Actuator Used: SS Series and HS Series
Application: Boom Swing and Grapple Swing

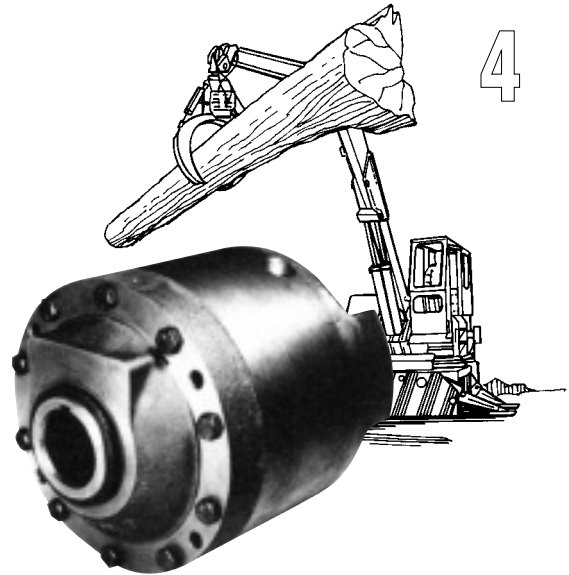

5 **Product:** Container Loading Systems
Actuator Used: HS Series
Application: Positioning Guides

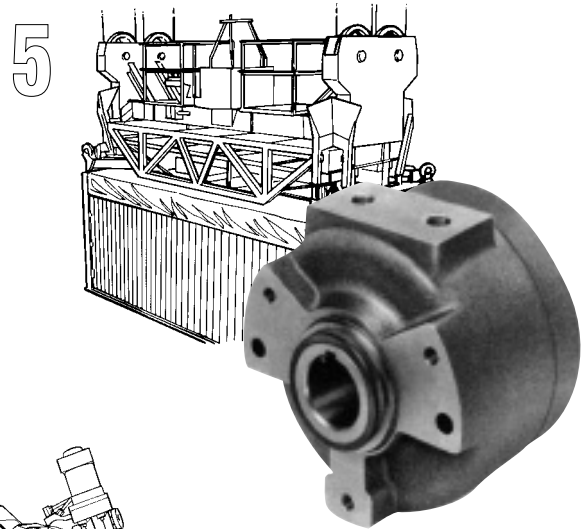

6 **Product:** Paint Spraying Robot
Actuator Used: MP Series
Application: Rotate Spray Head

7 **Product:** Brake Rotor Gage
Actuator Used: MP Series
Application: Parts Transfer

6

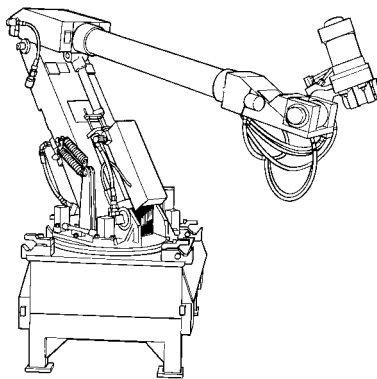
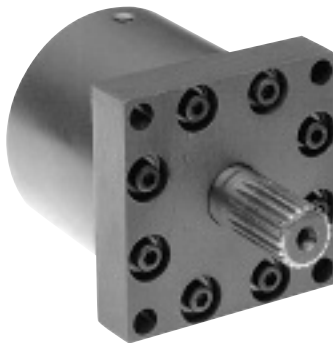

7

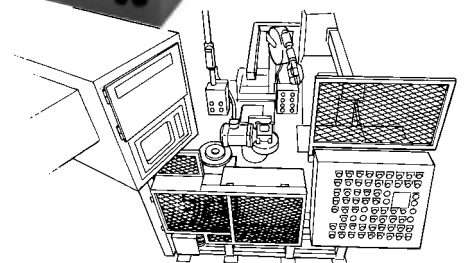
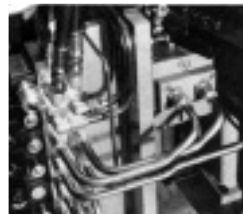

Applications (Cont'd)

8

Product: Animated Character
Actuator Used: MP Series
Application: Animated Character Joint Movement (Muscle)

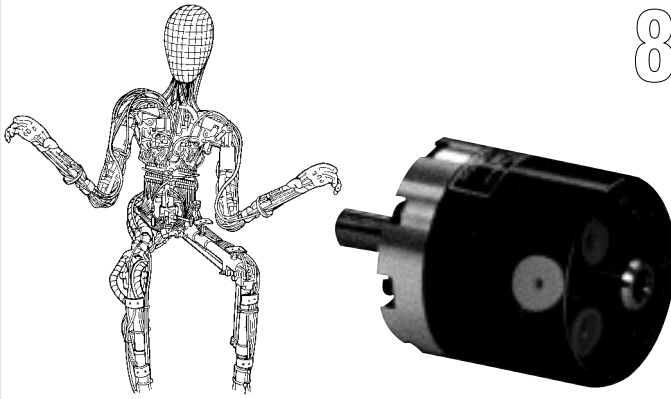

8

9

Product: Hydraulic Lift
Actuator Used: HS-10 and HS-15
Application: Residential and Commercial Refuse Handling System

9

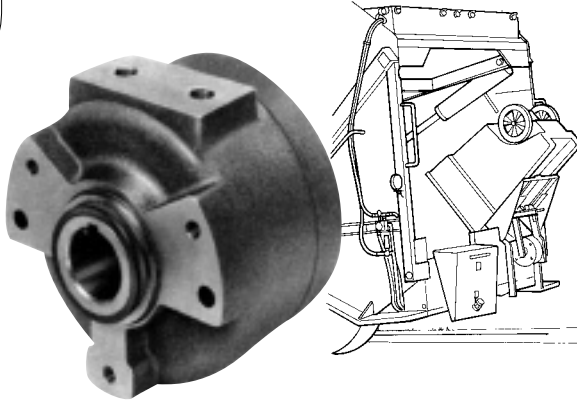

10

Product: Automated Machinery
Actuator Used: LP Series
Application: Parts Transfer

11

Product: Truck Mounted Booms
Actuator Used: SS and HS Series
Application: Boom Swing and Grapple Swing

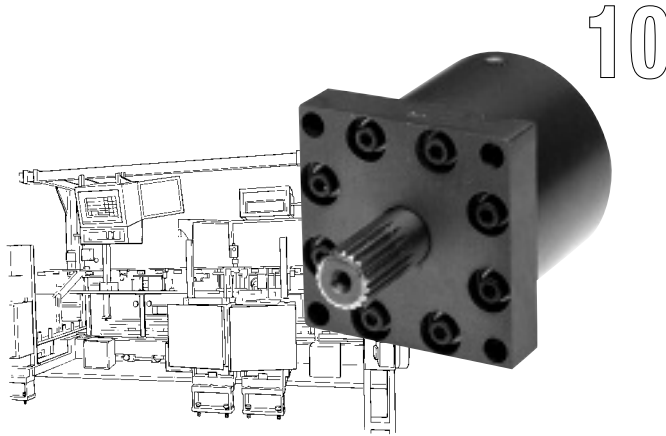

10

11

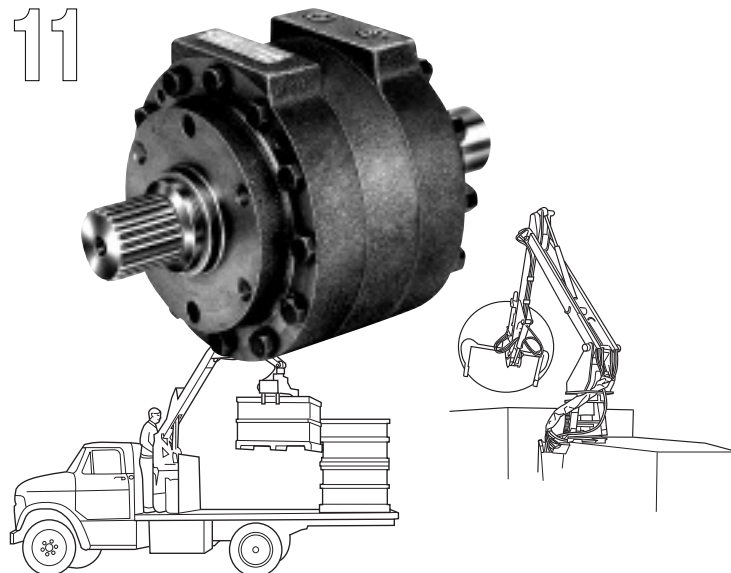

Applications

12 **Product:** Printing Presses
Actuator Used: SS Series
Application: Tensioning Device

12

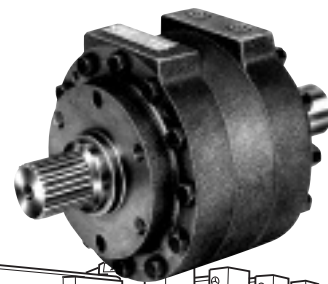

13 **Product:** Press Brakes
Actuator Used: HS Series
Application: Press Brake Drive

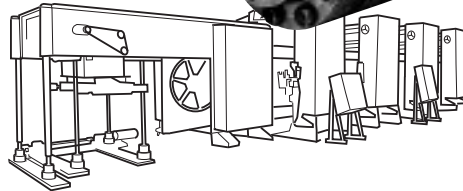

14 **Product:** Tube and Pipe Bender
Actuator Used: SS Series
Application: Tube Bending Drive



13

15 **Product:** Highway Maintenance Equipment
Actuator Used: HS Series
Application: Spraying Boom Swing

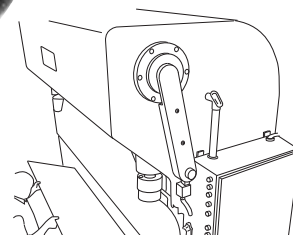

14

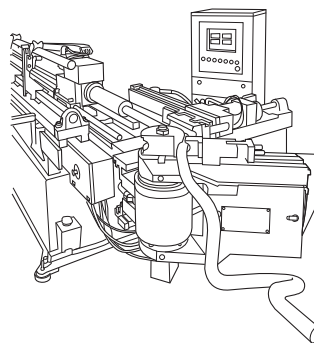

15

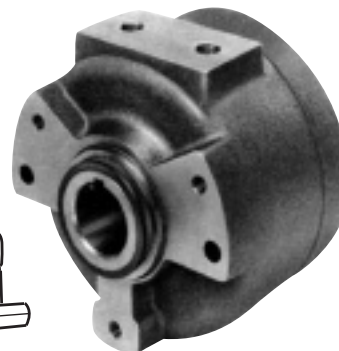
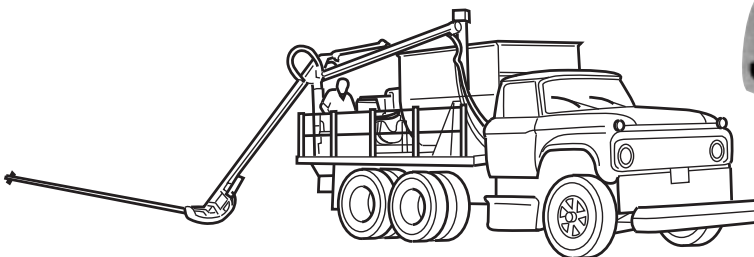

ENGINEERING DATA

THE BASICS

Rotary actuators convert fluid pressure into rotary power, and develop instant torque in either direction. Basic construction consists of an enclosed cylindrical chamber containing a stationary barrier and a central shaft with vane(s) affixed. Fluid pressure applied to either side of the vane will cause the shaft to rotate.

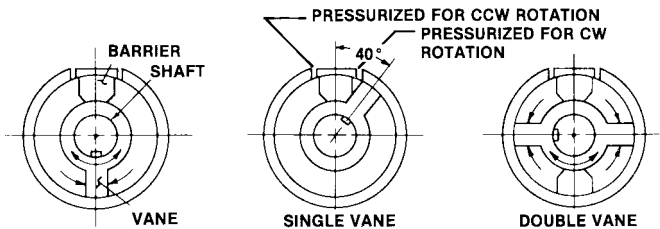

The output torque developed is determined by the area of the vane, the number of vanes, and the fluid pressure applied. Speed of rotation is dependent on the flow and pressure capacities of the hydraulic system. The majority of actuators are constructed with one or two vanes, but are available with three or more for special applications. The theoretical torque output of a multivane unit is greater by a factor equal to the number of vanes times the torque of a single vane unit at equal pressure. The maximum arc of rotation for any actuator depends on the size and construction of the unit, and will always be less than the number of vanes divided into 360° because of the space occupied by the internal barrier(s). The arc of a single vane is approximately 280°, a double vane 100° and a triple vane 50°.

VERSATILITY

Fluid Media — Actuators can be operated on either pneumatic or hydraulic pressure. The fluid can be air, oil, high water base fluid (HWBF), or fire resistant fluid. Actuators can be assembled with special seals and/or internally plated for specific fluids.

Mounting — Actuators can be mounted horizontally, vertically or any angle in between. Models are available with flange, end, base or foot mounting provisions.

Actuators are usually mounted in a stationary position with the shaft rotating, but also can be shaft mounted with the housing portion rotating. Some models require mounting dowels to resist torsional forces. See the specific actuator model for mounting details.

TYPICAL MOUNTINGS

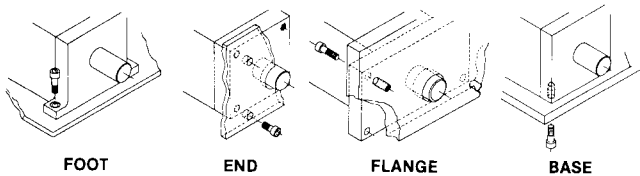

Control — Stopping, starting, acceleration and deceleration of actuators can be controlled by various types of valves in the fluid circuit.

External stops are recommended for most applications, although the arc of oscillation can be controlled by valves or positive internal stops (for light duty applications only).

In most cases special manifolds can be designed to mount servo-valves to the actuators allowing sophisticated control of all functions.

POSSIBLE APPLICATIONS

Rotary actuators are adaptable to a wide variety of uses in many different industries. The sketches shown give only an idea of the various possibilities. Actuators can perform a wide range of operations involving rotary or linear motion.

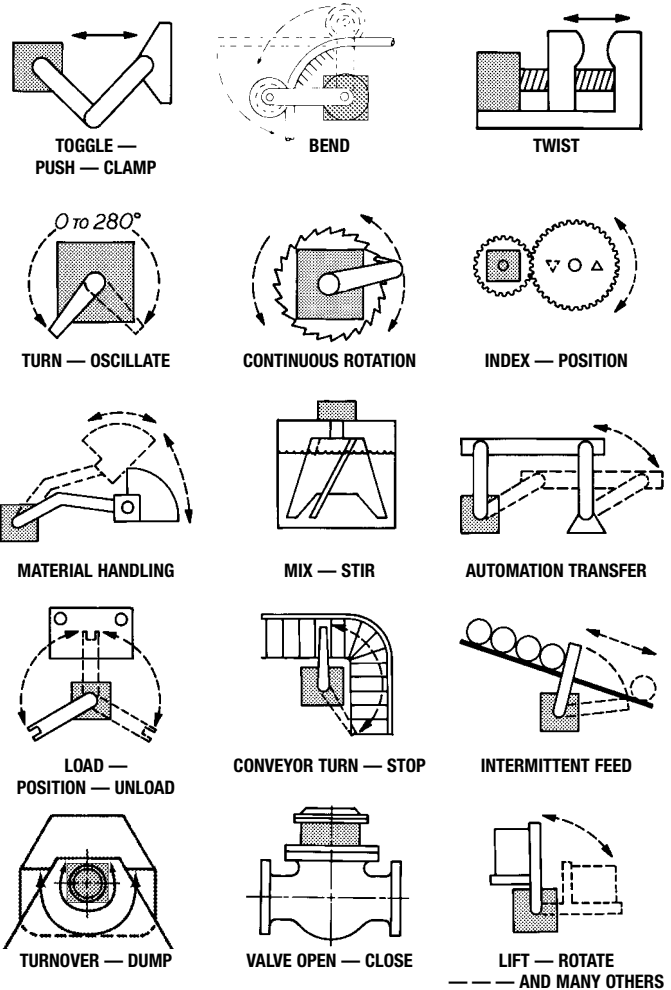

FACTORS TO CONSIDER WHEN APPLYING ACTUATORS

Service

Light Load — Heavy Load — consider weight of load and distance from actuator shaft.

Bearing Loads — heavy radial loads without external bearing support.

Shock Loads — consider dropped loads or mechanical failure of associated equipment. Also start - stop - jog and other non mechanical contact, hydraulic shock loads.

Rate of Oscillation — time to move load thru required angle. Also consider small angle - high rate applications.

Cycle Frequency — how often actuator is cycled. One cycle per minute, one cycle per week, etc.

External Stops — external stops should be used to limit angular travel as the actuator abutments (shoes) are not designed as mechanical stops.

Operating Press — should not exceed rated pressure of actuator.

ENGINEERING DATA

Environmental

- Temperature** — Hot example — foundry applications.
Cold example — cryogenic equip, outdoor equip.
- Dirt** — Examples, foundries, construction equipment
- Caustic** — Examples, valve operators, mixers plating tanks
- Humidity** — marine applications, outdoor
- Vibration** — machine tools, test equipment
- Radiation** — nuclear energy plants
- Electricity** — welding equipment
- Clean** — food processing, medical equipment

Maintenance

- Lubrication** — consult factory
- Filter Maintenance** — especially foundry and construction type applications
- Shaft Alignment** — close tolerance alignment or flexible couplings
- Proper Mounting** — rigid support, tight bolts, good coupling fits
- Long Term Storage** — fill with compatible oil
- External Stops** — tightness and proper location
- Fluid Media Conditioning** — water separators, lubricators, oil coolers
- Fittings and Hoses** — tightness and general condition
- Protective Shielding** — for high temperature or excessively dirty applications

GENERAL ENGINEERING NOTES

Selection of the proper sized actuator for an application is accomplished by determining the necessary torque to move the load at the required speed, the available fluid pressure and the necessary arc of rotation. Good design practice dictates a nominal over — capacity be designed into the load moving system.

Load torque, T_L (inch pounds) is the resistance to movement of the shaft due to a load force or mass, M , (pounds) acting at a distance, R , (inches) from the center of the shaft rotation. $T_L = MR$.

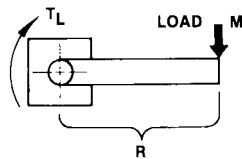

Motion will occur when the applied torque of the actuator exceeds the load torque. The velocity and acceleration, A , given to the load mass, M , is proportional to the excess torque or force, F .

$$A = \frac{F}{M} \text{ or } F = MA$$

Similarly, the load mass once set in motion must be stopped or decelerated with an opposing force $F = MA$. This deceleration force can be obtained by gradually restricting the flow of fluid to and from the actuator.

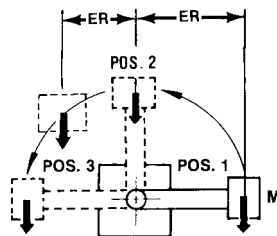

Caution:

Actuator should be protected from over pressurization during deceleration.

Lifting a mass in an arc causes the effective radius ER , to vary with the rotational position, becoming minimum at the vertical (90°) position. The load torque due to load force thus decreases from maximum at position 1 to minimum at position 2, and then reverses to aid rotation from position 2 to position 3. Restrictions of fluid flow and control of deceleration pressures is vitally necessary in this type of application.

Calculation of the amount and rate of energy dissipation required to stop a moving mass is possible if the variables such as velocity, mass, time, pressure, viscosity, etc., can be determined. In actual circuits these factors are inter-related and solution is often complex.

Good general practice requires that more cycle time be allowed for deceleration than for acceleration of a given mass.

A simplified calculation can be made if the assumption is made that the acceleration and deceleration are constant and uniform. The energy required to accelerate the mass must be equal to the energy to decelerate the mass. This simplifies to the following formulas:

$$\begin{array}{l} \text{Pressure (PSI accel) times} \\ \text{Rotation (Degrees accel)=} \\ \text{Pressure (PSI decel) times} \\ \text{Rotation (Degrees decel)} \end{array} \quad \text{OR} \quad \begin{array}{l} \text{Pressure (PSI accel) times} \\ \text{Time accel=} \\ \text{Pressure (PSI decel) times} \\ \text{Time decel} \end{array}$$

Example:

A mass accelerated uniformly for 50° @ 800 psi moves at constant velocity through use of flow-control valves until decelerated in the last 100° in 10 seconds @ 400 psi.

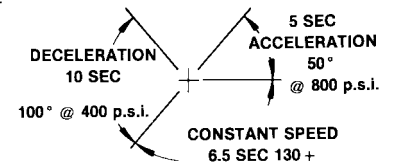

Note, however, that if the driving pressure were not removed during the deceleration period, the total deceleration pressure would be the sum of pressures, and at 1,200 psi could exceed the rating of the unit.

Actuator distributors can provide valuable assistance in solving specific circuit and application problems.

Direction and speed control for **slow speed and light loading** applications can be accomplished with relatively simple fluid circuits using hand-operated 4-way valves.

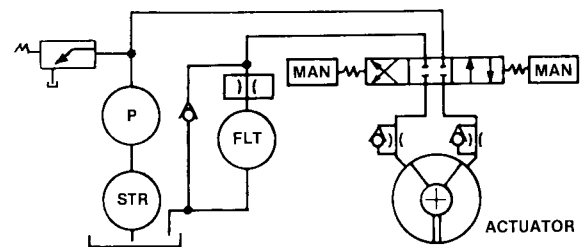

High speed and/or rapid cycling operation would suggest a commercially available solenoid-operated 4-way directional control valve and flow-control valves for better control of cycle motions, and the addition of fluid cooler, accumulators, and other components directed to specific system requirements.

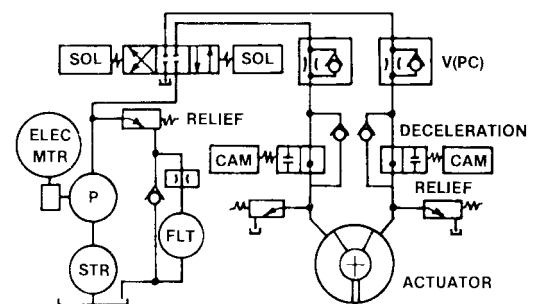

Severe shock and possible damage to the system can occur on hydraulic applications by sudden or complete restriction of outgoing fluid, which allows the moving mass to generate high surge or transient shock wave pressures which must not exceed the rating of the unit.

ENGINEERING DATA

Deceleration valves, actuated by cams or by limit switches, are often used to gradually restrict the fluid and stop the moving mass. Usually, relief valves plumbed as shown, or plumbed from one line to the other in each direction, will limit the generation of surge pressures to a safe value. Cross-port relief manifolds are available for most actuators. If cam valves are used, the cam shape should provide a gentle ramp transition, and the spool should be tapered to provide a gradual closing off of fluid.

As a general rule, external stops, mounted securely to the machine framework, should be used to stop the load. The shaft vanes should not contact the internal stops except under very light loads.

Air bleeding in hydraulic systems is usually not required if actuator is mounted with supply ports upward. In other positions, air will gradually dissolve in the oil and be carried away as the actuator is cycled. Special bleed connections are available as an optional feature on some actuators if specified when ordering.

Internal by-pass flow is always present to a small degree, and increases with increase of pressure. On air applications it must be recognized that on stall-out applications, under air pressure, there will be a small continuous by-pass flow.

Pure torque out-put from the actuator without external radial shaft bending loads is preferred to allow maximum bearing life. An arrangement with a semi-flexible coupling and the load shaft supported by separate bearings is recommended.

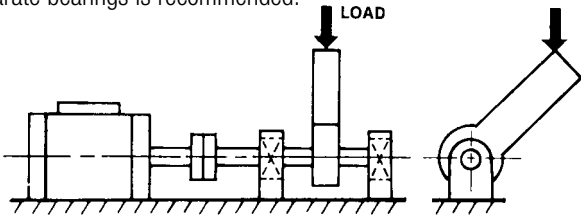

A similar arrangement is advised for power transmission through gears to eliminate gear load and separating forces from aggravating the actuator bearing load.

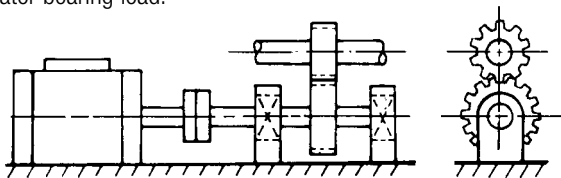

Where a flexible coupling cannot be used, very accurate alignment of the actuator and associated equipment is essential to prevent undue actuator bearing loading.

End thrust or axial loading of the actuator shaft is not advised. A thrust bearing, and the load driven through a sliding spline (or other means) is recommended to minimize internal wear for maximum actuator life.

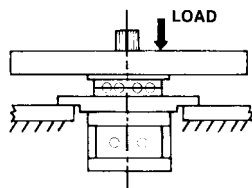

Temperature:

Standard actuators, unless otherwise specified, may be operated satisfactorily between minus 30°F and plus 250°F. Operation at higher temperatures requires special seal compounds.

Filtration:

Filtration of operating fluid to the 25 micron range is recommended.

Storage:

Actuators, when stored for any extended period of time, will require additional rust protection. Upon receipt of the actuator, remove port plugs, fill the actuator chambers with clean, mineral-base oil (or other fluid compatible with seal compounds), and replace plugs securely. Cover exterior surfaces with adequate rust-preventive material. Place in a poly bag and seal.

Installation:

Normal machinists' practice and care should be used in installing actuators. As for any oscillating type actuator, the most efficient means of transmitting the torque developed is through multiple tooth, involute spline or SAE 10-B spline. Suitable flange type adapters and straight connectors are covered under "Accessories" in the catalog. These are also available through the local distributor.

System Pressure:

Caution must be exercised in actuator sizing by making allowance for a pressure drop throughout the hydraulic system in which the actuator is installed. If an extensive system of piping, control valves, flow control valves, etc. is present, it is to be expected that full line pressure will not be available at the actuator inlet port.

Angular Velocity:

Angular velocity can be readily controlled by metering the amount of flow of fluid into or out of the actuator ports. Many designs of flow control valves are available on the market for this purpose. If greater flow is required than that available in the selected standard actuator, special larger size ports can be specified within reasonable limits.

Service and Repair:

Seals in actuators are readily replaced by qualified personnel trained in hydraulic equipment repair. Interchangeable replacement parts are available from factory. Always specify the serial number and bill of material of unit when ordering spare or replacement parts. Replacement of worn bearings may be accomplished by qualified personnel, but we recommend that such repairs be made by the Factory Repair Department so that units can be reconditioned to meet original performance specifications.

Distributors in principal cities throughout the U.S., Canada, Europe, and Asia can supply you with additional information. If you have any questions, contact your distributor, or the actuator factory.

An overhaul procedure which contains complete instructions for replacement of seals or other worn parts, and an exploded view and parts list for ordering replacement parts, is available from the factory.

Service operations should be performed by competent hydraulic equipment technicians to maintain high manufacturing quality standards.

Basic Formulas (Hydraulic)

L = Body Length (in.)

D = Body I.D. (in.)

d = Hub dia. (in.)

ARC = Degrees of Rotation

N = Number of Vanes

PSI = Lbs/Sq. Inch (Pressure)

Displacement Per Radian = $[N \cdot L(D^2 - d^2)] \div 8$ (in³/Rad.)

Theoretical Torque = $[N \cdot L(D^2 - d^2) \div 8]$ PSI (in-lb)

Actual Torque = Theoretical Torque • % efficiency (in-lb)

Total Displacement = $[L \cdot ARC \cdot N \cdot \pi (D^2 - d^2)] \div 1440$ (in³)

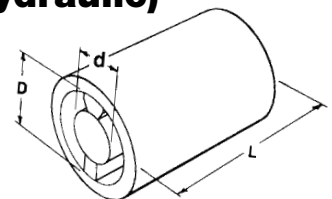

ENGINEERING DATA

HARMONIC MOTION DRIVES

Applications requiring the linear transfer of a load under controlled acceleration and deceleration are quite common. Within limits, this type of motion can be achieved thru a harmonic motion drive. An actuator driven, scotch yoke arrangement as shown in Figure 1 imparts this type motion. The scotch yoke converts the constant speed rotating motion to a sinusoidal motion producing maximum linear force for acceleration, maximum linear speed thru the middle of the actuator stroke, and maximum decelerating forces to slow and stop the load.

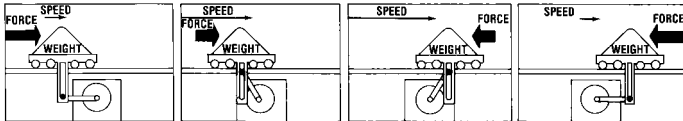

The following equations assume a constant actuator rotational velocity. This is sometimes difficult to achieve, particularly for short cycle times that result in a large load velocity. The inertia of the load will tend to drive the actuator during the deceleration phase. These forces may cause cavitation or physical damage to the actuator. Therefore, under certain conditions the actuator may require external assistance in decelerating the load.

A flow control in the discharge side of the actuator provides this assistance, assuring a positive-pressure throughout the cycle. The added resisting torque resulting from the discharge metering must be added to the driving torque requirement.

Equations of Motion

The equation of motion for a Scotch Yoke mechanism can be developed as follows:

Referring to Figure 1.

$$(1) s = r \cos \theta$$

and

$$(2) \theta = \omega t$$

Where

ω = angular velocity of crank (link 1), $\frac{\text{rad}}{\text{sec}}$
 t = time, sec.

r = crank length, in.

s = horizontal movement of load W from midpoint of travel, in.

The velocity of link 2, and thus load W , may be found by differentiating the movement with respect to time.

$$(3) v = \frac{d(-s)}{dt} = \frac{d(-r \cos \omega t)}{dt} = r\omega \sin \omega t$$

The acceleration of load W is found by differentiating its velocity with respect to time:

$$(4) a = \frac{dv}{dt} = \frac{d(r\omega \sin \omega t)}{dt} = r\omega^2 \cos \omega t$$

Therefore, when the crank rotates at constant angular velocity, the velocity and acceleration of the load can be determined for any position of the crank. Equation (4) indicates that maximum acceleration occurs when $\cos \omega t = 1$ or

$$(5) a \text{ max.} = r\omega^2$$

For a 180° crank throw, $\omega = \frac{\pi}{t'}$, where t' represents the time

required to transfer the load a distance of $2r$. Therefore,

$$(6) a \text{ max.} = r \left(\frac{\pi}{t'} \right)^2$$

This relation applies for any load W .

FIGURE 1. TYPICAL HARMONIC MOTION DRIVE ARRANGEMENT

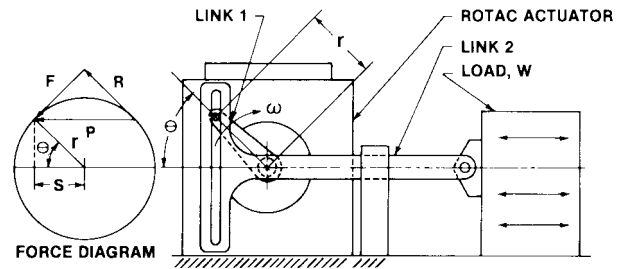

Required Torque

Consider an actuator powered Scotch Yoke mechanism moving a load as shown in Figure 1. Assume for simplicity that the system is frictionless. The forces acting on the actuator crank (link 1) are also shown in Figure 1.

$$(7) P = \frac{W}{g} a = \frac{W}{g} (r\omega^2 \cos \omega t)$$

$$(8) F = \frac{W}{g} (r\omega^2 \cos \omega t) (\sin \omega t)$$

$$(9) R = \frac{W}{g} (r\omega^2 \cos^2 \omega t)$$

Therefore, the required actuator torque at any time during the cycle is:

$$(10) T = (F)r = \frac{Wr^2\omega^2}{g} (\cos \omega t) (\sin \omega t)$$

The maximum torque requirement may be found by differentiating equation (10) with respect to time and setting the result equal to 0 as follows:

$$(11) \frac{dT}{dt} = \frac{Wr^2\omega^2}{g} \frac{d(\cos \omega t \sin \omega t)}{dt} = 0$$

$$\frac{Wr^2\omega^2}{g} [\omega \cos^2 \omega t - \omega \sin^2 \omega t] = 0$$

Since $\sin^2 \omega t = 1 - \cos^2 \omega t$, substitution into equation (11) yields

$$\cos^2 \omega t = 0.5$$

or

$$\cos \omega t = \sin \omega t = \sqrt{0.5}$$

Therefore, the maximum actuator torque requirement is:

$$(12) T \text{ max.} = (.5) \frac{Wr^2\omega^2}{g}$$

Recalling that $\omega = \frac{\pi}{t'}$ (t' = time for 180° crank throw)

and $g = 386.4 \text{ in/sec}^2$

$$(13) T \text{ max.} = \frac{(.5)(\pi)^2}{386.4} \times W \left(\frac{r}{t'} \right)^2 = .01277W \left(\frac{r}{t'} \right)^2 \text{ IN-LB with } r \text{ measured in inches.}$$

This expression may be used to determine the maximum actuator torque requirement for a frictionless system by knowing the load weight, crank arm length and the time required for 180° crank rotation.

In systems where friction must be considered, the required actuator torque will obviously be greater than that given by equation 13. The derivation of torque equations which consider the effects of friction becomes somewhat mathematically involved and will therefore not be repeated here.

ENGINEERING DATA

However, by considering only friction of the moving load and neglecting the crank friction forces along the vertical axis (vertical friction forces have little effect on torque) it can be shown that the maximum actuator torque is approximately:

$$(14) T_{max} = Wr[.02554 \frac{r}{(t')^2} \cos \omega t + \mu] \sin \omega t, \text{ in-lb}$$

where μ = coefficient of friction of moving load

$$\omega t = \cos^{-1} \left\{ -9.788 \frac{\mu(t')^2}{r} + .25 [1532.76 \frac{\mu^2(t')^4}{r^2} + 8]^{1/2} \right\}$$

ROTATIONAL SPEED OF ACTUATORS/PUMP CAPACITY REQUIRED

For hydraulic operation the time necessary for the actuator to make its travel arc can be figured with reasonable accuracy.

Where:

Arc=amount of rotation required (in degrees).

t=time, in seconds, for the actuator to make its arc of rotation.

Av=Angular velocity, in degrees per minute, for the actuator to make its arc of rotation.

Da=displacement, in cubic inches per radian, of the actuator.

GPM=gallons per minute required to rotate the actuator the specified arc in the specified time.

$$t = \frac{60 \cdot \text{Arc}}{Av}$$

$$Av = \frac{13235 \cdot \text{GPM}}{Da}$$

Example:

Calculate the time necessary to rotate an actuator 100°, that displaces 3.78 cubic inches per radian, with a five gallon per minute fluid supply.

$$Av = \frac{13235 \cdot \text{GPM}}{Da} = \frac{13235 \cdot 5}{3.78} = 17506.6 \text{ degrees per minute}$$

$$t = \frac{60 \cdot \text{Arc}}{Av} = \frac{60 \cdot 100}{17506.6} = .343 \text{ seconds}$$

Using the same basic formula, the GPM required to rotate an actuator a specified arc in a specified time can be figured.

$$\text{GPM} = \frac{Da \times Av}{13235}$$

Example:

Calculate the necessary pump capacity required to rotate an actuator that displaces 10.9 cubic inches per radian, 180° in .5 seconds.

$$Av = \frac{60 \cdot \text{Arc}}{t} = \frac{60 \cdot 180^\circ}{.5} = 21,600 \text{ degrees per minute}$$

$$\text{GPM} = \frac{Da \cdot Av}{13235} = \frac{10.9 \cdot 21,600}{13235} = 17.79 \text{ Gallons per minute}$$

SAMPLE PROBLEMS

A few typical Rotac application problems are presented here along with simplified solutions which can be used to approximate the torque requirement for a specific job. These formulas should be used only as a guide in the selection of an actuator since friction and other system characteristics are not considered.

The symbols used in the sample problems are defined as follows:

- a, b, ℓ Dimensional Characteristics of Load, IN.
- F Force, LB.
- g Acceleration of Gravity, (386.4 IN./SEC.²)
- Jm Polar (mass) Moment of Inertia, in-lb sec²
- r Radius, IN. (to the center of gravity of the weight)
- t Time, Sec. (per stroke or 1/2 cycle)
- T Torque, IN.-LB.
- m Mass of Load (Weight \div 386.4)
- α Angular Acceleration, RAD./SEC.²
- Θ Angular movement in radians (degrees per stroke \div 57.3)

Problem #1

Find the torque required to rotate a rectangular load (horizontally) thru a given arc in a specified time. (See fig. 1)

Solution:

$$T = \sum Jm\alpha$$

$\sum Jm = Jm_1 + Jm_2 \dots$ The sum of all polar mass moments of inertia being rotated.

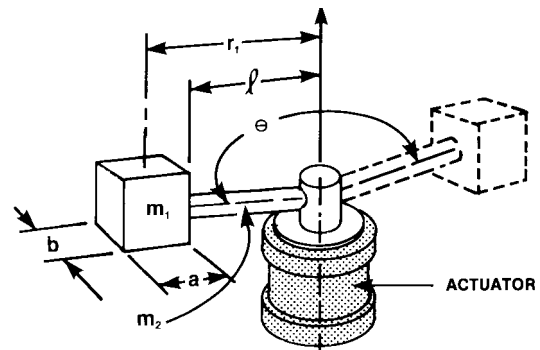

FIGURE 1

$Jm_1 \cong m_1 r_1^2$ (for applications where r is large in comparison to a & b)

$Jm_2 = \frac{m_2 \ell^2}{3}$ (for a straight rod or any straight symmetrical shape)

$\alpha = \frac{4\Theta}{t^2}$ (assumes 50% of rotating time for acceleration and 50% for deceleration)

Example #1

Find the torque necessary to rotate a 20 lb. weight, 160°, in .5 seconds. The weight is supported by a 36" long, 3 lb. rod. (a & b are 8.4 inches) ($r_1 = 40.2$ inches)

$$Jm_1 \cong m_1 r_1^2 = \frac{20}{386.4} (40.2)^2 = 83.64 \text{ in-lb sec}^2$$

$$Jm_2 = \frac{m_2 \ell^2}{3} = \frac{3 \div (386.4)}{3} 36^2 = 3.35 \text{ in-lb sec}^2$$

$$\Theta = \frac{160^\circ}{57.3^\circ} = 2.792 \text{ radians}$$

$$\alpha = \frac{4\Theta}{t^2} = \frac{4(2.792)}{.5^2} = 44.67 \text{ radians / sec}^2$$

$T = \sum Jm\alpha = (Jm_1 + Jm_2)\alpha = (83.64 + 3.35)44.67 = 3885 \text{ in-lb of torque required}$

Note: If r_1 is small in relation to a & b use: $Jm_1 = m_1 \left(\frac{a^2 + b^2}{12} + r^2 \right)$

ENGINEERING DATA

Example #2

(assume r_1 in example #1=12" all other parameters remain the same)

$$Jm_1 = m_1 \left(\frac{a^2 + b^2}{12} + r_1^2 \right) = \frac{20}{386.4} \left(\frac{8.4^2 + 8.4^2}{12} + 12^2 \right) = 8.06 \text{ in-lb sec}^2$$

$$l = r_1 - (a \div 2) = 12 - (8.4 \div 2) = 7.8$$

$$Jm_2 = \frac{m_2 l^2}{3} = \frac{3 \div (386.4) 7.8^2}{3} = .157 \text{ in-lb sec}^2$$

α = same as previous (44.67)

$$T = \sum Jm\alpha = (Jm_1 + Jm_2)\alpha = (8.06 + .157) 44.67 = 367 \text{ in-lb of torque required}$$

Problem 1A:

Find the torque required to lift a weight and rotate it vertically thru a specified arc in a specified time.

Solution:

$$T = \sum (Jm\alpha + Wr \cos\theta_s)$$

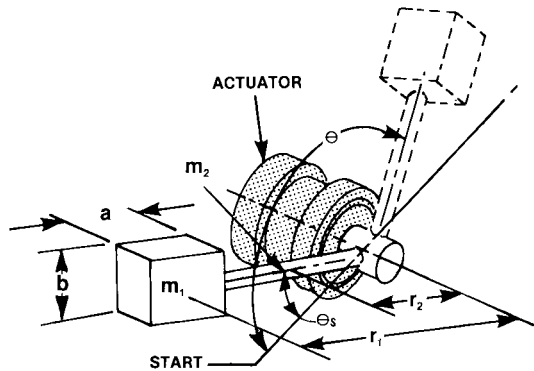

FIGURE 2

Note: $Jm\alpha$ is the torque required to move the load without the effect of gravity.

$Wr \cos\theta$ is the torque resulting from the effect of gravity on the load. The torque required changes as the angle changes, the maximum requirement at horizontal, lessening to zero at the vertical. The torque value is negative past vertical, gravitational forces actually aiding in producing torque.

Example #3

Find the torque required if the load in example # 1 is rotated vertically. Assume the starting angle (θ_s) is 20° .

Assume:

$Jm\alpha = T = 3885 \text{ in.-lb.}$ (from example #1) $w_1 = 20 \text{ lb.}$, $w_2 = 3 \text{ lb.}$, $r_1 = 40.2$, $r_2 = 20.1$

$$T = \sum (Jm\alpha + (w_1 r_1 + w_2 r_2) \cos \theta_s) = 3885 + (20 \cdot 40.2 + 3 \cdot 20.1) \cos 20^\circ = 4697 \text{ in.-lb. required at start.}$$

$$T_{\max} = \sum [Jm\alpha + (w_1 r_1 + w_2 r_2)] = [3885 + (20 \cdot 40.2 + 3 \cdot 20.1)] = 4749 \text{ in-lb}$$

Problem 2:

Find the torque required to rotate a thin hollow pipe about its transverse axis through a given angle in a specified time.

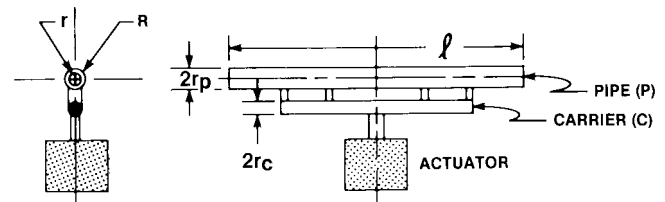

Solution:

$$T = Jm\alpha = (Jm_c + Jm_p) \alpha$$

For thin-walled pipe

$$Jm_p = \frac{m}{2} \left(r_p^2 + \frac{l^2}{6} \right)$$

For thick-walled pipe

$$Jm_p = \frac{m}{4} \left(R_p^2 + r_p^2 + \frac{l^2}{3} \right)$$

For solid-circular bar

$$Jm_c = \frac{m}{12} (3r_c^2 + l^2)$$

Assume:

50% (t) for acceleration
50% (t) for deceleration

Therefore,

$$\alpha = \frac{4\theta}{t^2}$$

Example:

Assume:

Carrier: — 1" dia. x 12" long steel bar (2.7 Lb.)
Pipe: — 2.88 I.D. x 3.00 O.D. x 36" long (steel) (6 Lb.)
Rotate pipe 180° in 2 secs.

$$m = \frac{W}{386.4}$$

$$T = (Jm_p + Jm_c) \alpha$$

$$Jm_p = \frac{m}{2} \left(r_p^2 + \frac{l^2}{6} \right) = \frac{.0155}{2} \left(1.44^2 + \frac{36^2}{6} \right) = 1.690 \text{ in-lb sec}^2$$

$$Jm_c = \frac{m}{12} (3r_c^2 + l^2) = \frac{.007}{12} (3(.5)^2 + 12^2) = .084 \text{ in-lb sec}^2$$

$$\alpha = \frac{4\theta}{t^2} = \frac{4(180 \div 57.3)}{2^2} = \frac{4(3.14)}{4} = 3.14 \text{ rad/sec}^2$$

$$T = (1.690 + .084) 3.14 = 5.57 \text{ in.-lb. torque required}$$

ENGINEERING DATA

Problem 3:

Find the torque required to open or close a door through a given angle in a specified time.

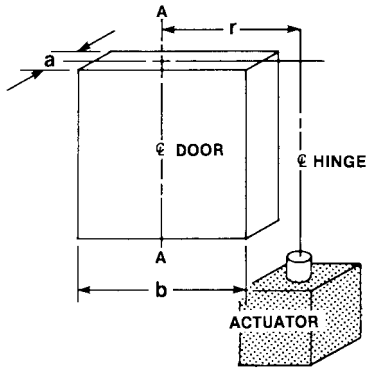

Solution:

$$T = Jm \text{ } \textcircled{C} \text{ hinge } \alpha$$

$$Jm_{A-A} = \frac{m}{12}(a^2 + b^2)$$

$$Jm \text{ } \textcircled{C} \text{ hinge} = Jm_{A-A} + mr^2$$

Assume:

50% (t) for acceleration
50% (t) for deceleration

Therefore,

$$\alpha = \frac{4\Theta}{t^2}$$

Example:

Find the torque necessary to open a 350 Lb. door 100° in .8 secs.

Assume:

door: a = 4", b = 36", r = 22", w = 350 Lb.

$$m = \frac{W}{386.4}$$

$$T = Jm \text{ } \textcircled{C} \text{ hinge } \alpha$$

$$Jm_{A-A} = \frac{m}{12}(a^2 + b^2) = \frac{.906}{12}(4^2 + 36^2) = 99.06 \text{ in-lb sec}^2$$

$$Jm \text{ } \textcircled{C} \text{ hinge} = Jm_{A-A} + (mr^2) = 99.06 + (.906(22^2)) = 537.56 \text{ in-lb sec}^2$$

$$\alpha = \frac{4\Theta}{t^2} = \frac{4(100 \div 57.3)}{.8^2} = \frac{6.98}{.64} = 10.91 \text{ rad./sec}^2$$

$$T = Jm \text{ } \textcircled{C} \text{ hinge } \alpha = 537.56(10.91) = 5864.12 \text{ in-lb. torque required}$$

Problem 4:

Find the torque required to rotate several plates of various thicknesses through a given angle in a specified time.

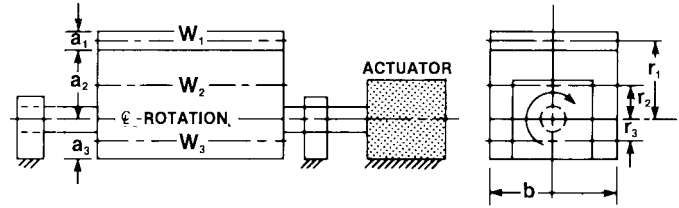

Solution:

$$T = Jm \text{ } \textcircled{C} \text{ Rotation } \alpha = \sum [(Jm_1 + Jm_2 + Jm_3) \alpha + (w_1 r_1 + w_2 r_2 + w_3 r_3)]$$

$$Jm_1 = \frac{M_1}{12}(a_1^2 + b_1^2) + m_1 r_1^2$$

$$Jm_2 = \frac{M_2}{12}(a_2^2 + b_2^2) + m_2 r_2^2$$

$$Jm_3 = \frac{M_3}{12}(a_3^2 + b_3^2) + m_3 r_3^2$$

Assume:

50% (t) for acceleration
50% (t) for deceleration

Therefore,

$$\alpha = \frac{4\Theta}{t^2}$$

Example:

Rotate three plates as shown, 180° in 2 secs.

Assume:

w_1 : $a_1 = .5$ ", $b_1 = 6$ " weight=10 Lb., $r_1 = 5.25$

w_2 : $a_2 = 5$ ", $b_2 = 6$ " weight=100 Lb., $r_2 = 2.5$

w_3 : $a_3 = 2$ ", $b_3 = 6$ " weight=40 Lb., $r_3 = 1.0$

$$m = \frac{W}{386.4}$$

$$T = Jm \text{ } \textcircled{C} \text{ Rotation } \alpha = \sum (Jm_1 + Jm_2 + Jm_3) \alpha$$

$$Jm_1 = \frac{m_1}{12}(a_1^2 + b_1^2) + m_1 r_1^2 = \frac{.026}{12}(.5^2 + 6^2) + .026(5.25)^2 = .795 \text{ in-lb sec}^2$$

$$Jm_2 = \frac{m_2}{12}(a_2^2 + b_2^2) + m_2 r_2^2 = \frac{.259}{12}(5^2 + 6^2) + .259(2.5)^2 = 2.94 \text{ in-lb sec}^2$$

$$Jm_3 = \frac{m_3}{12}(a_3^2 + b_3^2) + m_3 r_3^2 = \frac{.104}{12}(2^2 + 6^2) + .104(1.0)^2 = .451 \text{ in-lb sec}^2$$

$$\alpha = \frac{4\Theta}{t^2} = \frac{4(180 \div 57.3)}{2^2} = \frac{4(3.14)}{4} = 3.14 \text{ rad./sec}^2$$

$$T = \sum [(Jm_1 + Jm_2 + Jm_3) \alpha + (w_1 r_1 + w_2 r_2 + w_3 r_3)] = [(.795 + 2.94 + .451) 3.14 + (10 \times 5.25 + 100 \times 2.5 + 40 \times 1)] = 355.64 \text{ in-lb torque required}$$

ENGINEERING DATA

Problem 5:

Find the torque required to produce a given force as shown in the figure below.

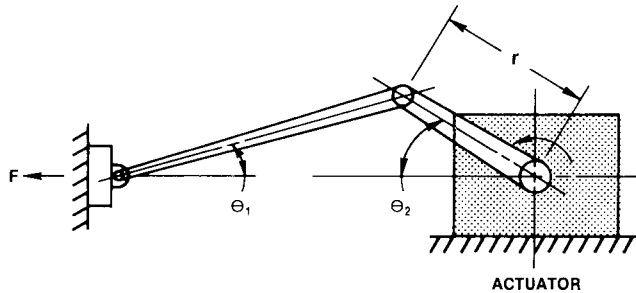

Solution:

$$T = \left[\frac{Fr \sin(\theta_1 + \theta_2)}{\cos\theta_1} \right]$$

Design Notes:

1. The design should be such that angles θ_1 and θ_2 are not permitted to go to zero degrees.
2. Force, F, must be less than the bearing capacity of the actuator.

Problem 6:

Find the torque required to produce a given force in a typical die closer application.

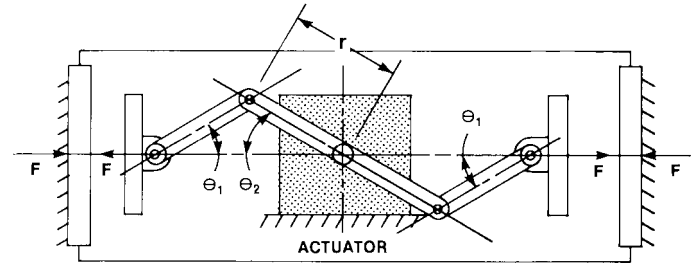

Solution:

$$T = \left[\frac{2Fr \sin(\theta_1 + \theta_2)}{\cos\theta_1} \right]$$

Design Notes:

1. The design should be such that angles θ_1 and θ_2 are not permitted to go to zero degrees.
2. Force, F, may be greater than the bearing capacity of the actuator since it is transmitted through the linkage, and not to the bearing.

REFERENCE DATA

PROPERTIES OF VARIOUS SOLIDS*

Solids	Polar mass Moment of inertia, Jm	Radius of gyration, K
<p>STRAIGHT ROD</p>	$J_{AA} = \frac{m l^2}{12}$ $J_{BB} = \frac{m l^2}{3}$ $J_{CC} = \frac{m l^2 \sin^2 \alpha}{3}$	$K_{AA} = \frac{l}{\sqrt{12}}$ $K_{BB} = \frac{l}{\sqrt{3}}$ $K_{CC} = l \sqrt{\frac{\sin^2 \alpha}{3}}$
<p>ROD BENT INTO A CIRCULAR ARC</p>	$J_{AA} = \frac{m r^2}{2} \left[1 - \frac{\sin \alpha \cos \alpha}{\alpha} \right]$ $J_{BB} = \frac{m r^2}{2} \left[1 + \frac{\sin \alpha \cos \alpha}{\alpha} \right]$	$K_{AA} = r \sqrt{\frac{1}{2} \left(1 - \frac{\sin \alpha \cos \alpha}{\alpha} \right)}$ $K_{BB} = r \sqrt{\frac{1}{2} \left(1 + \frac{\sin \alpha \cos \alpha}{\alpha} \right)}$
<p>CUBE</p>	$J_{AA} = J_{BB} = \frac{m a^2}{6}$	$K_{AA} = K_{BB} = \frac{a}{\sqrt{6}}$

* All axes pass through the center of gravity unless otherwise noted. W = total weight of the body. $m = \frac{W}{386.4}$

REFERENCE DATA

PROPERTIES OF VARIOUS SOLIDS* (CONTINUED)

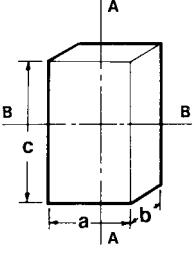
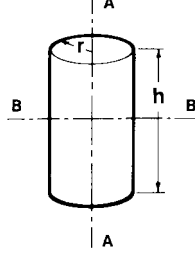
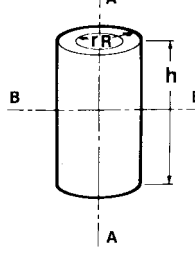
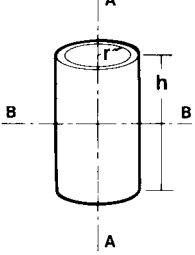
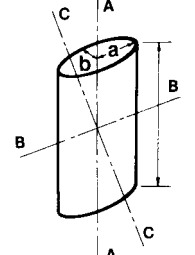
Solids	Polar mass Moment of inertia, Jm	Radius of gyration, K
<p>RECTANGULAR PRISM</p> 	$J_{AA} = \frac{m(a^2 + b^2)}{12}$ $J_{BB} = \frac{m(b^2 + c^2)}{12}$	$K_{AA} = \sqrt{\frac{a^2 + b^2}{12}}$ $K_{BB} = \sqrt{\frac{b^2 + c^2}{12}}$
<p>RIGHT CIRCULAR CYLINDER</p> 	$J_{AA} = \frac{mr^2}{2}$ $J_{BB} = \frac{m(3r^2 + h^2)}{12}$	$K_{AA} = \frac{r}{\sqrt{2}}$ $K_{BB} = \sqrt{\frac{3r^2 + h^2}{12}}$
<p>HOLLOW RIGHT CIRCULAR CYLINDER</p> 	$J_{AA} = \frac{m(R^2 + r^2)}{2}$ $J_{BB} = \frac{m(R^2 + r^2 + \frac{h^2}{3})}{4}$	$K_{AA} = \sqrt{\frac{R^2 + r^2}{2}}$ $K_{BB} = \sqrt{\frac{3R^2 + 3r^2 + h^2}{12}}$
<p>THIN HOLLOW CYLINDER</p> 	$J_{AA} = mr^2$ $J_{BB} = \frac{m}{2} \left(r^2 + \frac{h^2}{6} \right)$	$K_{AA} = r$ $K_{BB} = \sqrt{\frac{6r^2 + h^2}{12}}$
<p>ELLIPTICAL CYLINDER</p> 	$J_{AA} = \frac{m(a^2 + b^2)}{4}$ $J_{BB} = \frac{m(3b^2 + h^2)}{12}$ $J_{CC} = \frac{m(3a^2 + h^2)}{12}$	$K_{AA} = \sqrt{\frac{a^2 + b^2}{2}}$ $K_{BB} = \sqrt{\frac{3b^2 + h^2}{12}}$ $K_{CC} = \sqrt{\frac{3a^2 + h^2}{12}}$

REFERENCE DATA

PROPERTIES OF VARIOUS SOLIDS* (CONTINUED)

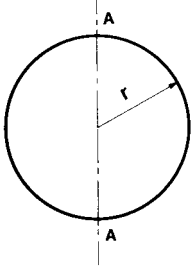
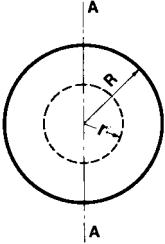
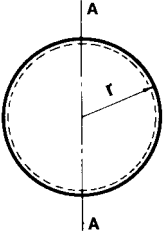
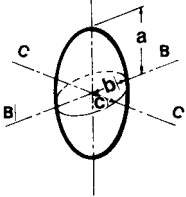
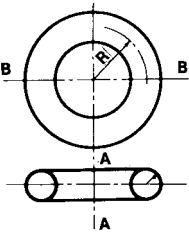
Solids	Polar mass Moment of inertia, Jm	Radius of gyration, K
<p>SPHERE</p> 	$J_{AA} = \frac{2mr^2}{5}$	$K_{AA} = \frac{2r}{\sqrt{10}}$
<p>HOLLOW SPHERE</p> 	$J_{AA} = \frac{2m}{5} \left(\frac{R^5 - r^5}{R^3 - r^3} \right)$	$K_{AA} = \frac{2}{5} \sqrt{\frac{R^5 - r^5}{R^3 - r^3}}$
<p>THIN HOLLOW SPHERE</p> 	$J_{AA} = \frac{2mr^2}{3}$	$K_{AA} = \frac{2r}{\sqrt{6}}$
<p>ELLIPSOID</p> 	$J_{AA} = \frac{m(b^2 + c^2)}{5}$ $J_{BB} = \frac{m(a^2 + c^2)}{5}$ $J_{CC} = \frac{m(a^2 + b^2)}{5}$	$K_{AA} = \sqrt{\frac{b^2 + c^2}{5}}$ $K_{BB} = \sqrt{\frac{a^2 + c^2}{5}}$ $K_{CC} = \sqrt{\frac{a^2 + b^2}{5}}$
<p>TORUS</p> 	$J_{AA} = m \left(R^2 + \frac{3R^2}{4} \right)$ $J_{BB} = m \left(\frac{R^2}{2} + \frac{5r^2}{8} \right)$	$K_{AA} = \frac{1}{2} \sqrt{4R^2 + 3r^2}$ $K_{BB} = \sqrt{\frac{4R^2 + 5r^2}{8}}$

* All axes pass through the center of gravity unless otherwise noted. W = total weight of the body. $m = \frac{W}{386.4}$

REFERENCE DATA

PROPERTIES OF VARIOUS SOLIDS* (CONTINUED)

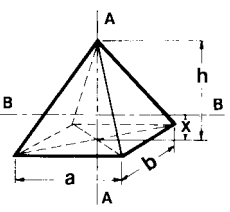
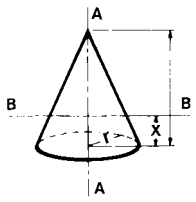
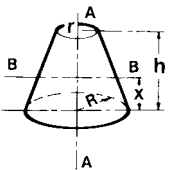
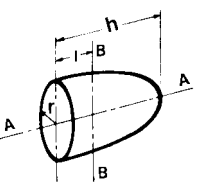
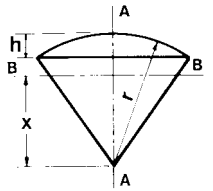
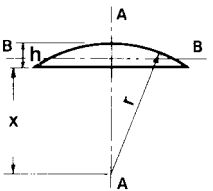
Solids	Distance to center of gravity, x	Polar mass Moment of inertia, Jm	Radius of gyration, K
<p>RIGHT RECTANGULAR PYRAMID</p> 	$x = \frac{h}{4}$	$J_{AA} = \frac{m(a^2 + b^2)}{20}$ $J_{BB} = \frac{m(b^2 + \frac{3h^2}{4})}{20}$	$K_{AA} = \sqrt{\frac{a^2 + b^2}{20}}$ $K_{BB} = \sqrt{1/80(4b^2 + 3h^2)}$
<p>RIGHT CIRCULAR CONE</p> 	$x = \frac{h}{4}$	$J_{AA} = \frac{3mr^2}{10}$ $J_{BB} = \frac{3m}{20} \left(r^2 + \frac{h^2}{4} \right)$	$K_{AA} = \frac{3r}{\sqrt{30}}$ $K_{BB} = \sqrt{3/80(4r^2 + h^2)}$
<p>FRUSTRUM OF RIGHT CIRCULAR CONE</p> 	$x = \frac{h(R^2 + 2Rr + 3r^2)}{4(R^2 + Rr + r^2)}$	$J_{AA} = \frac{3m}{10} \frac{(R^5 - r^5)}{(R^3 - r^3)}$	$K_{AA} = \sqrt{3/10 \frac{(R^5 - r^5)}{(R^3 - r^3)}}$
<p>PARABOLOID</p> 	$x = 1/3h$	$J_{AA} = \frac{mr^2}{3}$ $J_{BB} = \frac{m}{10} (3r^2 + h^2)$	$K_{AA} = \frac{r}{\sqrt{3}}$ $K_{BB} = \sqrt{1/10(3r^2 + h^2)}$
<p>SPHERICAL SECTOR</p> 	$x = 3/8(2r - h)$	$J_{AA} = \frac{m(3rh - h^2)}{5}$	$K_{AA} = \sqrt{\frac{3rh - h^2}{5}}$
<p>SPHERICAL SEGMENT</p> 	$x = \frac{3(2r - h)^2}{4(3r - h)}$ <p>For half sphere</p> $x = 3/8 r$	$J_{AA} = m \left(r^2 \frac{3rh}{4} + \frac{3h^2}{20} \right) \frac{2h}{3r - h}$	$K_{AA} = \sqrt{\frac{I}{W}}$

REFERENCE DATA

DEFINITIONS, ABBREVIATIONS AND SYMBOLS

ABBREVIATIONS:

BTU.	British Thermal Unit — 1 BTU = Heat required to raise temperature of one pound of water 1°F.
°C	Degrees Centigrade
CAL.	Calorie — 1 CAL. = Heat required to raise temperature of one gram of water 1°C.
C. C.	Cubic Centimeter
CU. FT.	Cubic Foot
CU. IN.	Cubic Inch
°F	Degrees Fahrenheit
FPS.	Feet per second
FT.	Feet (foot)
GAL.	U.S. Gallon
GPM.	Gallons per minute
HP.	Horsepower = Work at rate of 33,000 FT. LB./MIN.
IN.	Inch(es)
IPS	Inches per second
°K	Degrees Kelvin
LB.	Pound(s)
MIN.	Minute(s) of time
PSI	Pounds per square inch
REV.	Revolutions (of shaft or pump)
SEC.	Second(s) of time
SP. GR.	Specific Gravity — Ratio of the weight of a body to the weight of an equal volume of water at 4°C or other specified temperature.
SP. HT.	Specific Heat — Ratio of heat required to raise a unit weight of a substance 1°F. to the amount of heat required to raise an equal weight of water 1°F. at a certain temperature. (Hydraulic oil is approx. 0.45.)
SP. WT.	Specific weight or weight density = LB./CU.FT.; LB./CU. IN. or grams/C.C.
SQ. IN.	Square inch(es)

SYMBOLS:

A	Area
a	Linear acceleration (FPS ²), rate of change of velocity
α	Angular acceleration (Radians per SEC. ²)
C	Compressibility of oil (CU. IN.)
D	Density, mass per unit volume
E	Energy
F	Force, (LB.) an influence which produces or tends to produce, motion or change of motion.
f	Coefficient of friction
g	Acceleration of gravity (IPS ²) = 386.4 at sea level
He	Elevation Head
H _g	Mercury
H _p	Pressure head (static)
H _v	Velocity head
L	Gallons per minute (GPM)
M	Mass = $\frac{W}{386.4}$; or a mass which, with an unbalanced force of 1 LB. acting upon it, would have an acceleration of 1 IPS ² .
M _f	Mechanical friction
N	Revolutions per minute (RPM)
ΔP	Pressure differential (DROP)
P	Pounds per square inch (PSI)
r	Arm (torque), radius in inches
T	Torque (inch-pounds)
U	Velocity (FPS) rate of change of distance (length)
V	Volume (CU. IN.)
W	Weight (LB.) force which gravitation exerts on a material body.

CONVERSION TABLES

<p>TORQUE</p> <p>IN-LB x .1130 = N-m N-m x 8.851 = IN-LB N-m x 9.807 = Kgf-m Kgf-m x 86.799 = IN-LB</p>	<p>PRESSURE</p> <p>PSI x .06895 = BAR BAR x 14.5 = PSI Kpa x .1450 = PSI PSI x 6.895 = Kpa</p>	<p>VOLUME</p> <p>Cubic Inches x 16.39 = CU. CMS CU. CMS x .06102 = Cubic Inches Gallon x 3.785 = Liter Liter x .264 = Gallon Gallon x 3785 = CU.CMS CU. CMS x .0002642 = Gallon</p>	<p>MASS</p> <p>Kg x 2.2046 = Lbs Lbs x .4536 = Kg</p> <p>POWER</p> <p>Hp x .7457 = Kw</p>
---	--	---	--

REFERENCE DATA

DEFINITIONS BY FORMULAS

ACCELERATION	$a = \frac{F}{M} = \frac{Fg}{W}$ <p>From $F = Ma$ and $M = \frac{W}{g}$</p> $\alpha = \text{Radians/SEC.}^2 = \frac{\text{Degrees/SEC.}^2}{57.3}$
FORCE	$F = AP$
FRICTION	$M_f = W \times f$ Note: Static (or breakaway) friction coefficient is greater than kinetic (or moving) friction coefficient
GRAVITY	$g = 386.4 \text{ in. / SEC.}^2$ (at sea level)
HORSEPOWER	$HP = \frac{FU}{550} = \frac{LP}{1714} = \frac{TN}{63,025}$
MASS	$M = \frac{W}{g}$ or, at sea level, $= \frac{W}{32.2}$, or $= \frac{W \text{ (grams)}}{980}$ or $\frac{W}{386.4}$ NOTE: Mass is constant regardless of altitude.
ORIFICE AREA	See pressure drop
PRESSURE	$P = \frac{F}{A}$ (consistent units)
PRESSURE DROP	<p>For oil hydraulic systems, the following will approximate pressure drop thru "short orifice" (1/4 to 1/2-inch long-length not over 3 times diameter)</p> $\Delta P = \frac{0.001056L^2}{A^2}$ <p>For specified pressure drop:</p> $A \text{ (required)} = \frac{0.0325L}{\sqrt{\Delta P}}$
RADIAN	<p>Arc (of circle) = Length of radius (see velocity, angular)</p> $\text{In degrees} = \frac{360}{2\pi} = \frac{180}{\pi} = 57.3^\circ$
SPRING RATE	$\frac{F}{\text{Distance compressed (or stretched) where distance is from the free length.}}$
TORQUE	$T = F \times r = \frac{HP \times 63.025}{N} = \frac{CU. IN. / REV \times P}{2\pi}$
VELOCITY, Angular	$\text{Radians/SEC.} = \frac{\text{Degrees/SEC.}}{57.3}$
Flow	$U = 0.321 \frac{L}{A}$



FLOW RATE FORMULAS

$$GMP = 3.117 AV$$

$$RPS = \frac{.0333 AVq}{D}$$

$$\text{Rad/Sec} = 2 \pi (\text{RPS})$$

GPM = Gallons per minute

RPS = Revolutions per second

Rad/Sec = Radians per second

Where:

A = Port area (in²)

V = Flow velocity in feet per sec.

q = Amount of rotation (degrees)

D = Total displacement of actuator (in³)

PROVIDING the "MUSCLE" for your lifting, turning, indexing, opening, closing, clamping, mixing, bending, testing, steering. . . **applications.**

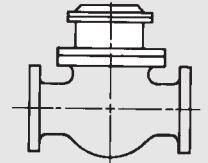

VALVE OPEN—CLOSE

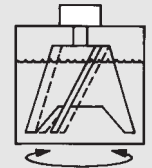

MIX—STIR

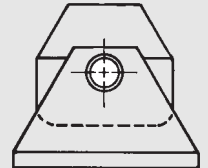

TURNOVER—DUMP

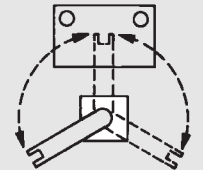

LOAD—POSITION—UNLOAD

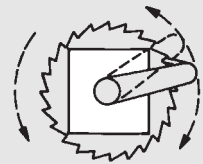

CONTINUOUS ROTATION



TURN—OSCILLATE

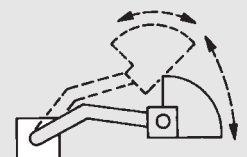

MATERIAL HANDLING

FLOW RATE DATA

	MODEL	SAE STRAIGHT THREAD PORT SIZE	PORT DIAMETER TUBE I.D. ①	PORT AREA (IN ²)	ACTUATOR DISPLACEMENT		FLOW RATE AND ANGULAR VELOCITY AT 10 FPS OIL VELOCITY			TIME (SEC.) PER STROKE	FLOW RATE AND ANGULAR VELOCITY AT 15 FPS OIL VELOCITY			TIME (SEC.) PER STROKE
					IN ³ TOTAL	IN ³ RADIAN	GPM	RAD/SEC	RPS		GPM	RAD/SEC	RPS	
MEDIUM PRESSURE	MPJ-11-1V	3/8-24	.117	.0107	.835	.178	.33	7.22	1.15	.65	.50	10.87	1.73	.43
	-2V				.557	.357		3.52	.56			.45	5.43	
	MPJ-22-1V	1/2-20	.187	.0275	3.820	.815	.86	4.07	.65	1.16	1.28	6.10	.97	.77
	-2V				2.560	1.631		2.02	.32			.78	3.03	
	MPJ-32-1V	7/8-14	.435	.1493	9.2	1.88	4.63	9.47	1.51	.52	6.95	14.2	2.26	.34
	-2V				6.6	3.78		4.72	.75			.37	7.07	
	MPJ-34-1V	7/8-14	.435	.1493	18.4	3.76	4.63	4.74	.75	1.03	6.95	7.10	1.13	.69
	-2V				13.0	7.44		2.40	.38			.73	3.59	
	MPJ-63-1V	1 1/16-12	.532	.2223	53.3	10.90	6.93	2.44	.39	1.99	10.39	3.67	.58	1.33
	-2V				38.0	21.77		1.22	.19			1.42	1.84	
	MPJ-84-1V	1 5/16-12	.760	.4537	127.4	26.07	14.14	2.09	.33	2.34	21.21	3.13	.50	1.56
	-2V				91.0	52.14		1.04	.17			1.63	1.57	
	MPJ-105-1V	1 5/8-12	1.01	.8012	253.3	51.83	24.97	1.85	.29	2.63	37.96	2.78	.44	1.76
	-2V				181.0	103.71		.93	.15			1.85	1.39	
	MPJ-116-1V	1 7/8-12	1.26	1.247	412.9	84.50	38.87	1.77	.28	2.76	58.30	2.66	.42	1.84
	-2V				295.0	169.04		.88	.14			1.98	1.33	
	MPJ-128-1V	1 7/8-12	1.26	1.247	588.4	120.41	38.87	1.24	.20	3.93	58.30	1.86	.30	2.62
	-2V				420.3	240.83		.62	.10			2.78	.93	
SS-1-1V	7/16-20	.152	.0182	5.86	1.20	.57	1.82	.29	2.69	.85	2.72	.43	1.79	
-2V				4.19	2.40		.91	.14			1.92	1.36		.22
SS-4-1V	9/16-18	.245	.0472	18.62	3.81	1.47	1.48	.24	3.29	2.20	2.23	.35	2.19	
-2V				13.29	7.62		.74	.12			2.35	1.11		.18
SS-8-1V	9/16-18	.245	.0472	39.09	8.00	1.47	.71	.11	6.91	2.20	1.06	.17	4.60	
-2V				60.84	12.45		.84	.13			5.79	1.27		.20
SS-12-1V	3/4-16	.334	.0876	43.46	29.90	2.73	.42	.07	4.13	4.10	.63	.10	2.76	
-2V				43.46	24.90		4.63	2.00			.32	2.44		6.95
SS-25-1V	7/8-14	.435	.1493	43.46	24.90	4.63	2.00	.32	2.44	6.95	3.01	.48	1.62	
-2V				195.46	40.00		14.14	1.36			.22	3.59		21.21
SS-40-1V	1 5/16-12	.760	.4537	139.62	80.00	14.14	.68	.11	2.56	21.21	1.02	.16	1.71	
-2V				317.63	65.00		14.14	.84			.13	5.83		21.21
SS-65-1V	1 5/16-12	.760	.4537	226.88	130.00	14.14	.42	.07	4.17	21.21	.63	.10	2.79	
-2V				635.25	130.00		24.97	.74			.12	6.61		37.46
SS-130-1V	1 5/8-12	1.010	.8012	453.75	260.00	24.97	.37	.06	4.72	37.46	.55	.09	3.15	
-2V														
HIGH PRESSURE	26R-2-1V	3/4-16	.334	.0876	9.35	1.91	2.73	5.50	.87	.89	4.10	8.24	1.31	.59
	-2V				6.67	3.82		2.74	.44			.63	4.13	
	26R-5-1V	3/4-16	.334	.0876	21.20	4.34	2.73	2.42	.39	2.02	4.10	3.63	.58	1.34
	-2V				15.10	8.68		1.21	.19			1.96	1.82	
	26R-10-1V	7/8-14	.435	.1493	49.30	10.12	4.63	1.76	.28	2.78	6.95	2.64	.42	1.85
	-2V				35.40	20.24		.88	.14			1.98	1.32	
	26R-17-1V	1-1/16-12	.532	.2223	82.60	16.90	6.93	1.58	.25	3.10	10.39	2.37	.38	2.06
	-2V				59.00	33.80		.79	.13			2.14	1.18	
	26R-31-1V	1-5/16-12	.760	.4537	199.50	30.60	14.14	1.78	.28	2.75	21.21	2.67	.42	1.83
	-2V				106.80	61.20		.89	.14			1.98	1.33	
	26R-62-1V	1-5/16-12	.760	.4537	304.00	62.20	14.14	.88	.14	5.58	21.21	1.31	.21	3.72
	-2V				217.00	124.40		.44	.07			3.99	.66	
	26R-124-1V	1-7/8-12	1.26	1.247	598.00	122.00	38.87	1.22	.19	4.09	58.30	1.83	.29	2.66
	-2V				427.00	244.00		.61	.10			2.78	.92	
	HS-1.5-1V	9/16-18	.245	.0472	7.33	1.50	1.47	3.77	1.30	.93	2.20	5.66	.90	.86
	HS-2.5-1V	9/16-18	.245	.0472	12.22	2.50	1.47	2.26	.36	2.16	2.20	3.39	.54	1.44
	HS-4.0-1V	9/16-18	.245	.0472	19.55	4.00	1.47	1.41	.23	3.46	2.20	2.12	.34	2.30
	HS-6.0-1V	3/4-16	.334	.0876	31.08	6.36	2.73	1.65	.26	2.95	4.10	2.48	.39	1.97
HS-10-1V	3/4-16	.334	.0876	46.62	9.54	2.73	1.10	.18	4.43	4.10	1.65	.26	2.96	
HS-15-1V	3/4-16	.334	.0876	73.30	15.00	2.73	.70	.11	6.97	4.10	1.05	.17	4.65	
SS-.2A-1V	—	.125	.0123	.98	.20	.38	7.34	1.17	.67	.57	11.02	1.75	.44	
SS-.5A-1V	3/8-24	.117	.0107	2.20	.45	.34	2.87	.46	1.71	.50	4.30	.68	1.14	
-2V				1.57	.90		1.43	.23	1.22		2.15	.34	.81	

NOTE: ① INLET HOLE DIA. IN MPJ-22 & SS-.2A UNITS

Engineering Data

	MODEL	SAE STRAIGHT THREAD PORT SIZE	PORT DIAMETER TUBE I.D. ①	PORT AREA (IN ²)	ACTUATOR DISPLACEMENT		FLOW RATE AND ANGULAR VELOCITY AT 20 FPS OIL VELOCITY			TIME (SEC.) PER STROKE	FLOW RATE AND ANGULAR VELOCITY AT 25 FPS OIL VELOCITY			TIME (SEC.) PER STROKE
					IN ³ TOTAL	IN ³ RADIAN	GPM	RAD/SEC	RPS		GPM	RAD/SEC	RPS	
MEDIUM PRESSURE	MPJ-11-1V-2V	3/8-24	.117	.0107	.835 .557	.178 .357	.67	14.95 7.22	2.30 1.15	.33 .22	.83	18.10 9.05	2.88 1.44	.26 .17
	MPJ-22-1V-2V	1/2-20	.187	.0275	3.820 2.560	.815 1.631	1.71	8.13 4.04	1.29 .64	.56 .39	2.14	10.16 5.06	1.62 .80	.46 .31
	MPJ-32-1V-2V	7/8-14	.435	.1493	9.2 6.6	1.88 3.78	9.26	18.95 9.43	3.02 1.50	.26 .19	11.58	23.68 11.79	3.77 1.88	.21 .15
	MPJ-34-1V-2V	7/8-14	.435	.1493	18.4 13.0	3.76 7.44	9.26	9.47 4.79	1.51 .76	.52 .36	11.58	11.84 5.99	1.88 .95	.41 .29
	MPJ-63-1V-2V	1 1/16-12	.532	.2223	53.3 38.0	10.90 21.77	13.85	4.89 2.45	.79 .39	1.00 .71	17.32	6.11 3.06	.97 .49	.80 .57
	MPJ-84-1V-2V	1 5/16-12	.760	.4537	127.4 91.0	26.07 52.14	28.28	4.18 2.09	.66 .33	1.17 .84	35.35	5.22 2.61	.83 .42	.94 .67
	MPJ-105-1V-2V	1 5/8-12	1.01	.8012	253.3 181.0	51.83 103.71	49.95	3.71 1.85	.59 .30	1.32 .94	62.43	4.64 2.32	.74 .37	1.05 .75
	MPJ-116-1V-2V	1 7/8-12	1.26	1.247	412.9 295.0	84.50 169.04	77.73	3.54 1.77	.56 .28	1.38 .99	97.16	4.43 2.21	.70 .35	1.10 .79
	MPJ-128-1V-2V	1 7/8-12	1.26	1.247	588.4 420.3	120.41 240.83	77.73	2.49 1.24	.40 .20	1.97 1.40	97.16	3.11 1.55	.49 .25	1.57 1.12
	SS-1-1V-2V	7/16-20	.152	0.182	5.86 4.19	1.20 2.40	1.13	3.63 1.81	.58 .29	1.35 .96	1.41	4.54 2.27	.72 .36	1.08 .77
SS-4-1V-2V	9/16-18	.245	.0472	18.62 13.29	3.81 7.62	2.94	2.97 1.49	.47 .24	1.65 1.17	3.67	3.71 1.86	.59 .30	1.32 .94	
SS-8-1V	9/16-18	.245	.0472	39.09	8.00	2.94	1.41	.23	3.45	3.67	1.77	.28	2.76	
SS-12-1V-2V	3/4-16	.334	.0876	60.84 43.46	12.45 29.90	5.46	1.69 .84	.27 .13	2.89 2.07	6.83	2.11 1.06	.34 .17	2.31 1.65	
SS-25-1V	7/8-14	.435	.1493	43.46	24.90	9.26	4.01	.64	1.22	11.58	5.01	.80	.97	
SS-40-1V-2V	1 5/16-12	.760	.4537	195.46 139.62	40.00 80.00	28.28	2.72 1.36	.43 .22	1.80 1.28	35.35	3.40 1.70	.54 .27	1.44 1.03	
SS-65-1V-2V	1 5/16-12	.760	.4537	317.63 226.88	65.00 130.00	28.28	1.68 .84	.27 .13	2.92 2.08	35.35	2.09 1.05	.33 .17	2.33 1.67	
SS-130-1V-2V	1 5/8-12	1.010	.8012	635.25 453.75	130.00 260.00	49.96	1.48 .74	.24 .12	3.30 2.36	62.43	1.85 .92	.29 .15	2.64 1.89	
HIGH PRESSURE	26R-2-1V-2V	3/4-16	.334	.0876	9.35 6.67	1.91 3.82	5.46	10.99 5.50	1.75 .88	.44 .32	6.83	13.74 6.88	2.19 1.09	.36 .25
	26R-5-1V-2V	3/4-16	.334	.0876	21.20 15.10	4.34 8.68	5.46	4.85 2.43	.77 .39	1.01 .72	6.83	6.06 3.04	.96 .48	.81 .57
	26R-10-1V-2V	7/8-14	.435	.1493	49.30 35.40	10.12 20.24	9.26	3.52 1.76	.56 .28	1.39 .99	11.58	4.40 2.20	.70 .35	1.11 .79
	26R-17-1V-2V	1-1/16-12	.532	.2223	82.60 59.00	16.90 33.80	13.86	3.16 1.58	.50 .25	1.55 1.10	17.32	3.95 1.97	.63 .31	1.24 .88
	26R-31-1V-2V	1-5/16-12	.760	.4537	199.50 106.80	30.60 61.20	28.28	3.56 1.78	.57 .28	1.37 .98	35.35	4.45 2.22	.71 .35	1.10 .78
	26R-62-1V-2V	1-5/16-12	.760	.4537	304.00 217.00	62.20 124.40	28.28	1.75 .88	.28 .14	2.79 1.99	35.35	2.19 1.09	.35 .17	2.23 1.59
	26R-124-1V-2V	1-7/8-12	1.26	1.247	598.00 427.00	122.00 244.00	77.73	2.45 1.22	.39 .19	2.00 1.43	97.16	3.06 1.53	.49 .24	1.60 1.14
	HS-1.5-1V	9/16-18	.245	.0472	7.33	1.50	2.94	7.54	1.20	.65	3.67	9.43	1.50	.52
	HS-2.5-1V	9/16-18	.245	.0472	12.22	2.50	2.94	4.52	.72	1.08	3.67	5.66	.90	.86
	HS-4.0-1V	9/16-18	.245	.0472	19.55	4.00	2.94	2.83	.45	1.73	3.67	3.54	.56	1.38
HS-6.0-1V	3/4-16	.334	.0876	31.08	6.36	5.46	3.31	.53	1.48	6.83	4.13	.66	1.18	
HS-10-1V	3/4-16	.334	.0876	46.62	9.54	5.46	2.20	.35	2.22	6.83	2.76	.44	1.77	
HS-15-1V	3/4-16	.334	.0876	73.30	15.00	5.46	1.40	.22	3.49	6.83	1.75	.28	2.79	
SS-2A-1V	—	.125	.0123	.98	.20	.77	14.69	2.34	.33	.96	18.36	2.92	.27	
SS-5A-1V-2V	3/8-24	.117	.0107	2.20 1.57	.45 .90	.67	5.73 2.87	.91 .47	.85 .61	.84	7.16 3.59	1.14 .57	.68 .47	

ABBREVIATIONS GPM - GALLONS PER MINUTE FPS - FEET PER SECOND RPS - REVOLUTIONS PER SECOND RAD/SEC - RADIANS PER SECOND

Engineering Data

PSI	20	40	60	80	100	150	200	250	500	750	1000	1250	1500	1750	2000	2250	2500	2750	3000
4500			SS-40 MP-128				SS-8			MP-34					SS-1				
4000								26R-17				26R-2							
3500			MP-105		SS-12			MP-63	SS-4		26R-2			SS-1					
3000			MP-116		MP-84		MP-63		MP-34		MP-32								
2500									26R-5										
2000					SS-12	MP-63		26R-10		26R-2 MP-32	SS-1								
1750			MP-105	SS-12 MP-84				SS-4								SS-5A			
1500									MP-32	SS-1					SS-5A				
1250			SS-12		MP-63		SS-4	MP-34			MP-22				SS-5A				
1000						SS-4	MP-34		26R-2 SS-1	MP-22		SS-5A							
900			MP-84					26R-5											
800				MP-63															
700					SS-4	MP-34													
600																			
500				SS-4			MP-32	SS-1		SS-5A									
400			SS-4 MP-63		MP-34		SS-1		SS-5A										
300						SS-1 MP-32		MP-22 26R-2			MP-11								
200				MP-34 LP-24	SS-1 MP-32, LP-24	LP-22	MP-22	SS-5A		MP-11									
100		LP-24	SS-1 MP-34, LP-24	SS-1 MP-32	LP-22	SS-5A MP-22			MP-11										
80				LP-22		LP-12													
60			MP-32		MP-22			MP-11											
40	LP-24	LP-22	LP-22	MP-22 LP-12	LP-12	LP-11	MP-11												
35																			
30					LP-11	MP-11													
25																			
20	LP-22	LP-12	LP-12		MP-11														
15			LP-11																
10	LP-12		MP-22																
5		LP-11	MP-11																
0	LP-11		MP-11																

NOTES



Micromatic

LOW PRESSURE PNEUMATIC

- 5 Standard Sizes
- 150 PSI
- Up to 570 in/lbs of Torque
- Small - As Light As 10 oz.
- Quick Delivery
- Economical
- Adjustable Stop Control
- Electrical End Position Indicator

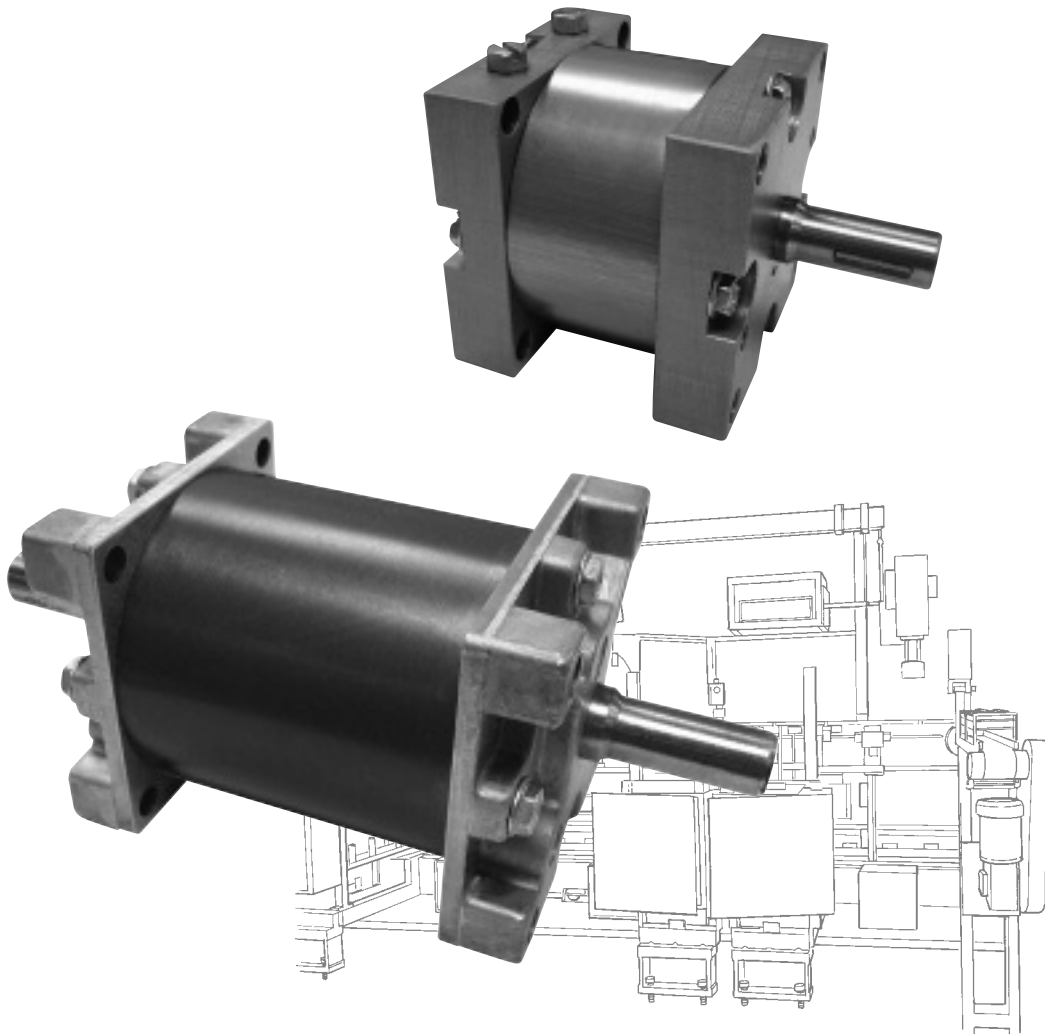

PROVIDING the “MUSCLE” for your lifting, turning, indexing, opening, closing, clamping, mixing, bending, testing, steering. . . **applications.**

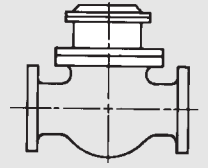

VALVE OPEN—CLOSE

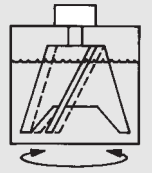

MIX—STIR

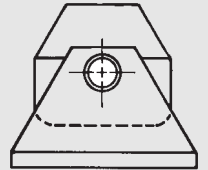

TURNOVER—DUMP

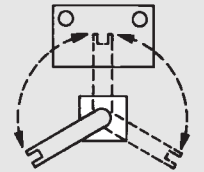

LOAD—POSITION—UNLOAD

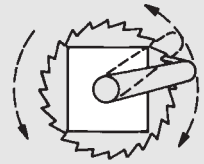

CONTINUOUS ROTATION



TURN—OSCILLATE

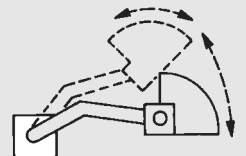

MATERIAL HANDLING

PNEUMATIC LP MODELS

**SINGLE AND DOUBLE VANE
LOW PRESSURE 150 PSI MAX.**

LP-11, LP-12, LP-22 & LP-24

NOTE: ALL LP MODEL ACTUATORS ARE DESIGNED TO OPERATE ON DRY, NON-LUBRICATED AIR. CONSULT FACTORY FOR SPECIFIC RECOMMENDATIONS.

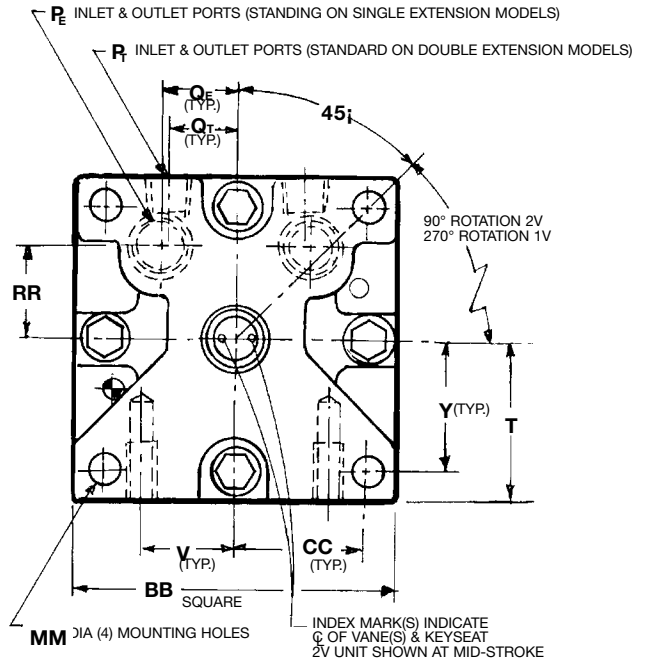
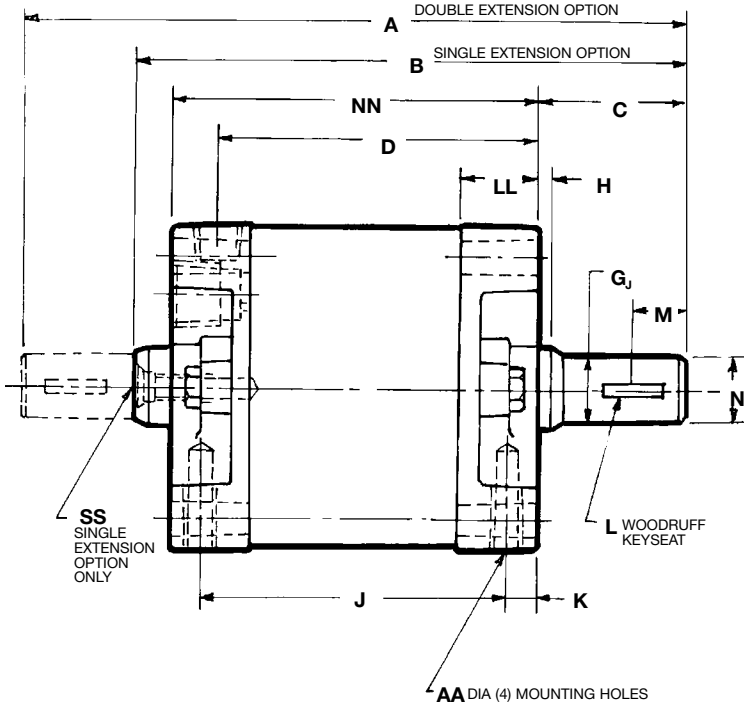

FOR LP-11 & LP-12

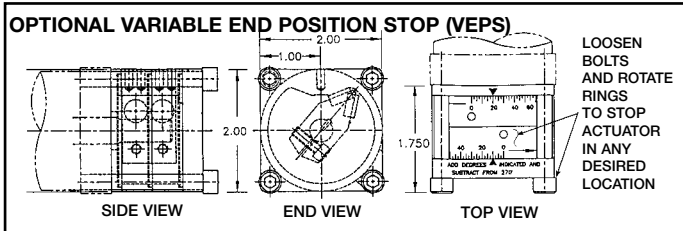

FOR LP-22 & LP-24

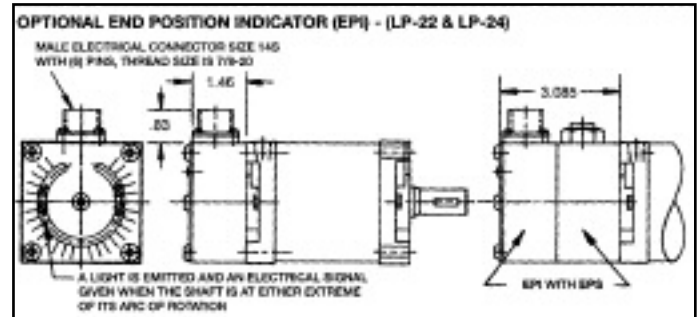
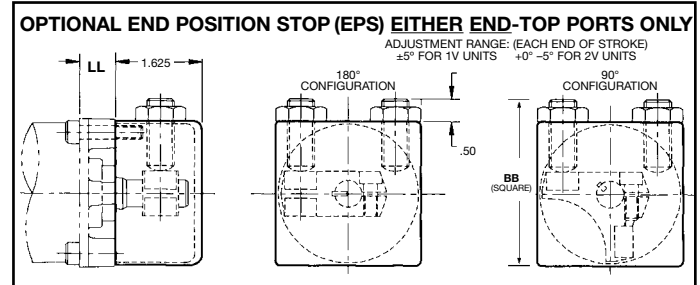

PERFORMANCE

SINGLE VANE 270° ROTATION (±1°)									
MODEL	TORQUE IN-LBS (N•m)					VOLUMETRIC DISP. IN ³ (cm ³)		WEIGHT Lb (Kg)	THRUST LOAD Lb (Kg)
	50 PSI (3.4 BAR)	75 PSI (5.2 BAR)	100 PSI (6.9 BAR)	125 PSI (8.6 BAR)	150 PSI (10.3 BAR)	Per 270°	Per RAD		
	LP-11	4 (.45)	7 (.79)	11 (1.24)	14 (1.58)	17 (1.92)	.839 (13.75)	.178 (2.92)	.58 (.26)
LP-12	10 (1.13)	16 (1.81)	23 (2.60)	29 (3.28)	36 (4.07)	1.68 (27.54)	.356 (5.83)	.75 (.34)	8 (3.63)
LP-22	25 (2.83)	41 (4.63)	57 (6.44)	73 (8.25)	89 (10.06)	3.86 (63.27)	.819 (13.42)	2.1 (.96)	12 (5.44)
LP-24	51 (5.76)	84 (9.49)	116 (13.11)	148 (16.72)	180 (20.34)	7.68 (125.9)	1.63 (26.72)	3.1 (1.41)	12 (5.44)

DOUBLE VANE 90° ROTATION (±1°)									
MODEL	TORQUE IN-LBS (N•m)					VOLUMETRIC DISP. IN ³ (cm ³)		WEIGHT Lb (Kg)	THRUST LOAD Lb (Kg)
	50 PSI (3.4 BAR)	75 PSI (5.2 BAR)	100 PSI (6.9 BAR)	125 PSI (8.6 BAR)	150 PSI (10.3 BAR)	Per 90°	Per RAD		
	LP-11	11 (1.24)	19 (2.15)	26 (2.94)	34 (3.84)	42 (4.75)	.559 (9.16)	.356 (5.83)	.62 (.28)
LP-12	26 (2.94)	43 (4.86)	59 (6.67)	75 (8.48)	92 (10.40)	1.12 (18.36)	.713 (11.69)	.81 (.37)	8 (3.63)
LP-22	58 (6.55)	94 (10.62)	130 (14.69)	166 (18.76)	202 (22.83)	2.56 (41.96)	1.63 (26.72)	2.2 (1.00)	12 (5.44)
LP-24	129 (14.58)	209 (23.62)	289 (32.66)	370 (41.81)	450 (50.85)	5.14 (84.24)	3.27 (53.60)	3.3 (1.51)	12 (5.44)

APPLICATION DATA DIMENSIONS IN INCHES (METRIC)

	LP-11	LP-12	LP-22	LP-24
A	4.00 (101.60)	5.00 (127.00)	6.32 (160.53)	8.32 (211.33)
B	3.18 (80.77)	4.18 (106.17)	5.25 (133.35)	7.25 (184.15)
C	1.00 (25.40)	1.00 (25.40)	1.41 (35.81)	1.41 (35.81)
D	1.75 (44.45)	2.75 (69.85)	3.06 (77.72)	5.06 (128.52)
G_J	.44 DIA. (11.18)	.44 DIA. (11.18)	.75 DIA. (19.05)	.75 DIA. (19.05)
H	.09 (2.29)	.09 (2.29)	.12 (3.05)	.12 (3.05)
J	1.63 (41.40)	2.63 (66.80)	2.63 (66.80)	4.63 (117.60)
K	.19 (4.80)	.19 (4.80)	.44 (11.18)	.44 (11.18)
L	1/16x1/2 #204 (1.59x12.70)	1/16x1/2 #204 (1.59x12.70)	1/8x5/8 #405 (3.18x15.88)	1/8x5/8 #405 (3.18x15.88)
M	.38 (9.65)	.38 (9.65)	.50 (12.70)	.50 (12.70)
N*	.3735 DIA. (9.487)	.3735 DIA. (9.487)	.6235 DIA. (15.837)	.6235 DIA. (15.837)
P_E	1/8-27 NPTF	1/8-27 NPTF	1/8-27 NPTF	1/8-27 NPTF
P_T	#10-32	#10-32	1/8-27 NPTF	1/8-27 NPTF
Q_E	.48 (12.19)	.48 (12.19)	.65 (16.51)	.65 (16.51)
Q_T	.44 (11.17)	.44 (11.17)	.65 (16.51)	.65 (16.51)
T**	1.030 (26.16)	1.030 (26.16)	1.530 (38.86)	1.530 (38.86)
V	.60 (15.24)	.60 (15.24)	.88 (22.35)	.88 (22.35)
Y	.84 (21.34)	.84 (21.34)	1.25 (31.75)	1.25 (31.75)
AA	#10-24 .38DP	#10-24 .38DP	1/4-20 .50DP	1/4-20 .50DP
BB	2.06 (52.32)	2.06 (52.32)	3.06 (77.72)	3.06 (77.72)
CC	.84 (21.34)	.84 (21.34)	1.25 (31.75)	1.25 (31.75)
LL	.50 (12.70)	.50 (12.70)	.75 (19.05)	.75 (19.05)
MM	.21 (5.33)	.21 (5.33)	.27 (6.86)	.27 (6.86)
NN	2.00 (50.80)	3.00 (76.20)	3.50 (88.90)	5.50 (139.70)
RR	.60 (15.24)	.60 (15.24)	.85 (21.59)	.85 (21.59)
SS	#10-24UNC-2B TAP .50 DEEP (12.70)	#10-24UNC-2B TAP .50 DEEP (12.70)	#1/4-20UNC-2B TAP .62 DEEP (15.75)	#1/4-20UNC-2B TAP .62 DEEP (15.75)

*± .0005 IN. (0.01 MM)

**± .005 IN. (0.13 MM)

TEST PARAMETERS — AIR			
MODEL	MAX BREAK PSI (BAR)	BY-PASS LEAKAGE-MAX ALLOWABLE	
		CUBIC FT. PER MIN. AT 100 PSI (6.9 BAR)	CUBIC CM. PER MIN. AT 100 PSI (6.9 BAR)
LP-11-1V	15 (1.03)	.20	5665
LP-11-2V	12 (.83)	.25	7080
LP-12-1V	12 (.83)	.20	5665
LP-12-2V	10 (.69)	.25	7080
LP-22-1V	10 (.69)	.20	5665
LP-22-2V	10 (.69)	.25	7080
LP-24-1V	10 (.69)	.20	5665
LP-24-2V	10 (.69)	.25	7080

IMPORTANT NOTES:

- External stops should be used to limit angular travel as the actuator abutments (shoes) are not designed as mechanical stops.
- Consult factory for applications requiring low breakaway and maximum torque output.

LP-11, LP-12, LP-22 & LP-24

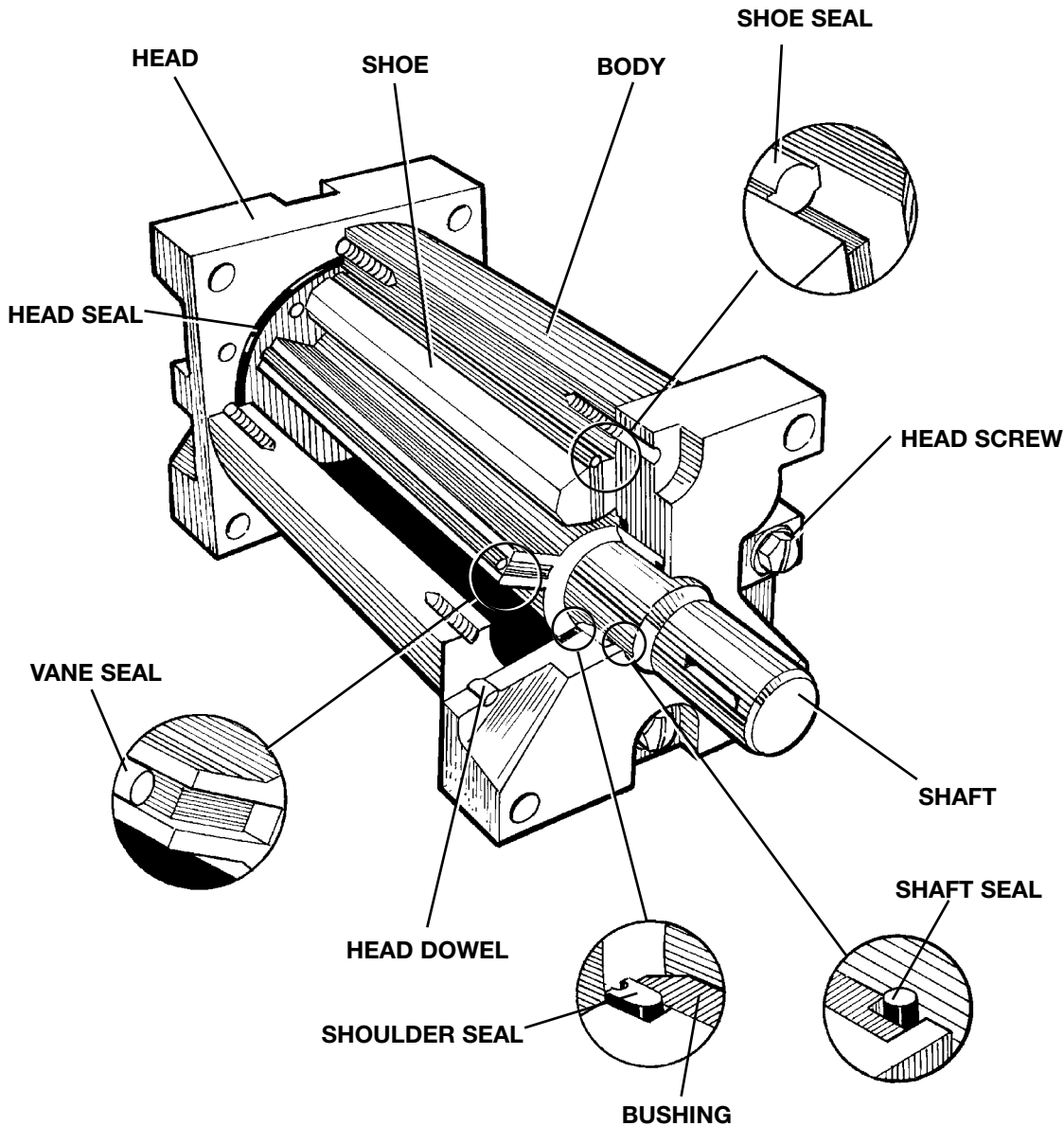

HOW TO ORDER

Sample: LP 22 2V DE TP

Model _____

Size _____

Number of Vanes _____
 1V—Single Vane
 2V—Double Vane

Shaft Extension _____
 SE—Single Extension
 DE—Double Extension

Port Options _____
 TP—Top Ports
 EP—End Ports

OPTIONS

EPS2 EPI2

EPI ELECTRICAL POSITION INDICATOR*			
SIZE	SWITCH TYPE	FUNCTION	SWITCHING VOLTAGE
1	REED SWITCH	SPST NORMALLY OPEN	5-120 VDC/VAC 50/60 HZ
2	HALL EFFECT SOURCING	NORMALLY OPEN PNP OUTPUT	6-24 VDC
3	HALL EFFECT SINKING	NORMALLY OPEN NPN OUTPUT	6-24 VDC

*For LP-22, LP-24 only at this time

VERS (For LP-11 and LP-12 only)
 EPS1/180° (LP-22 and LP-24 only)
 EPS2/90° (LP-22 and LP-24 only)

In order that your actuator order be processed promptly, please furnish complete information as shown by example. For special seal compounds or other special features, please consult Micromatic.



Micromatic

MP Models

1,000 PSI

MEDIUM PRESSURE

11 Standard Sizes

1,000 PSI

Up to 216,730 in/lbs of Torque

Higher Pressures Available

As Light As 4 oz.

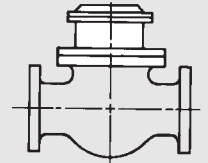
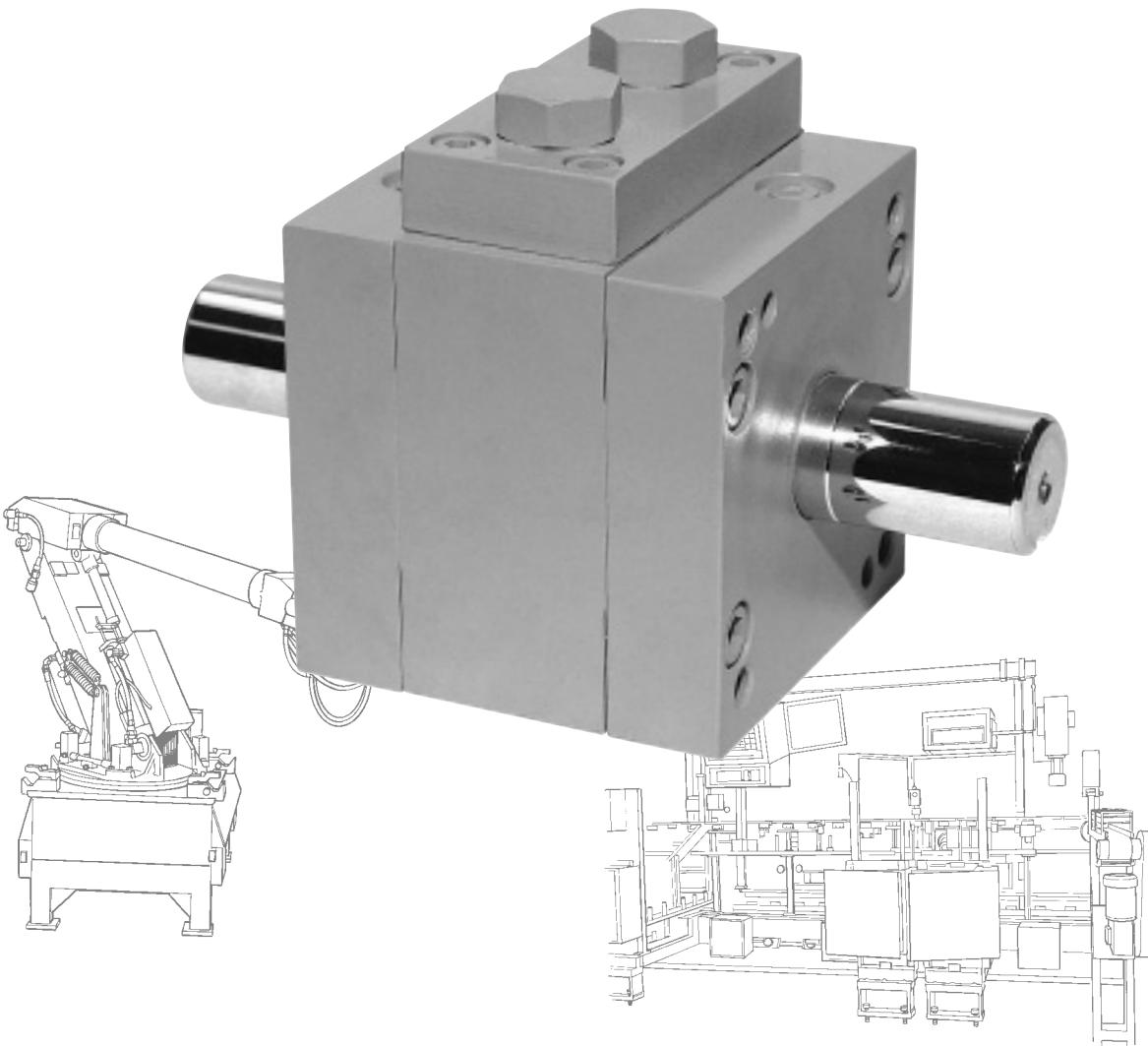

VALVE OPEN—CLOSE

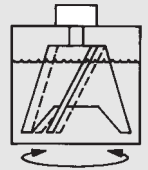

MIX—STIR

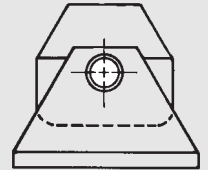

TURNOVER—DUMP

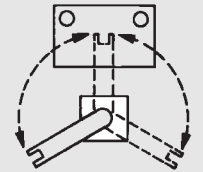

LOAD—POSITION—UNLOAD

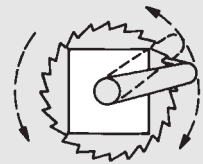

CONTINUOUS ROTATION



TURN—OSCILLATE

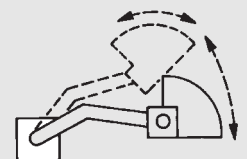

MATERIAL HANDLING

PROVIDING the “MUSCLE” for your lifting, turning, indexing, opening, closing, clamping, mixing, bending, testing, steering... **applications.**

MP MODELS MEDIUM PRESSURE 1000 P.S.I. STD.

(For Higher Operating Pressures or High Water Base Configurations Contact Plant)

MINI MPR-1x.4 & MPR-1x1 Medium Pressure 750 PSI Max.

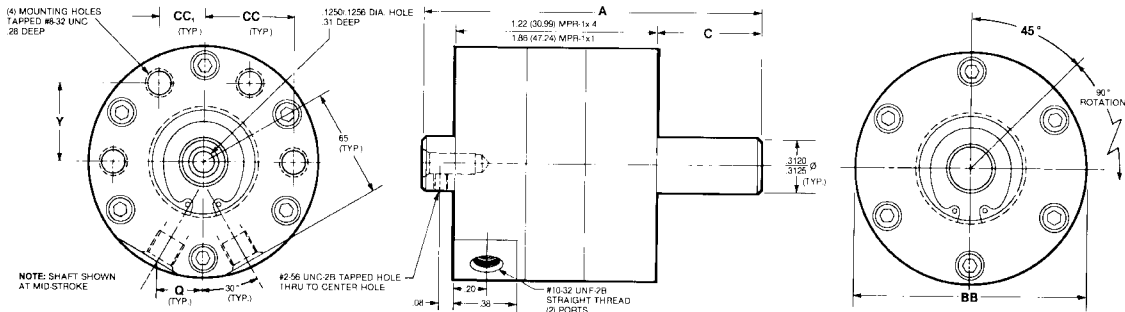

MPJ-11 & MPJ-22

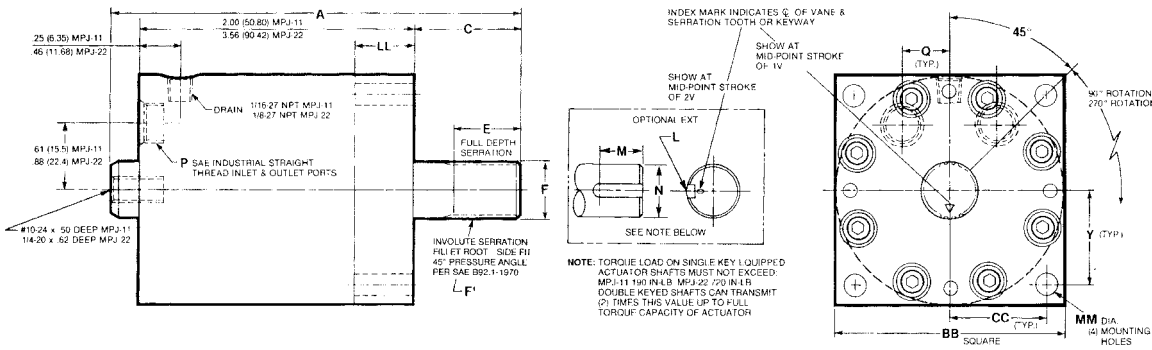

MP-32 THRU MP-128

END BASE MOUNTING

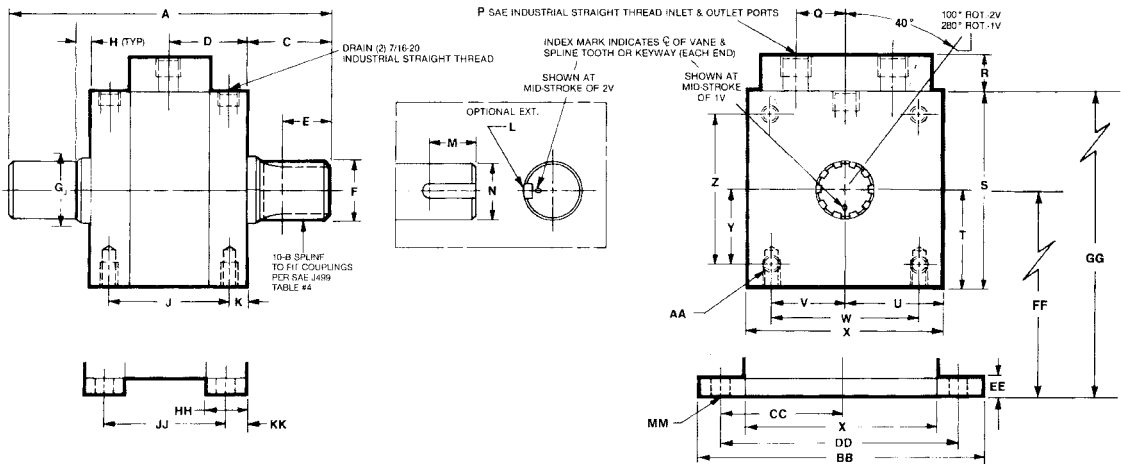

FOOT MOUNTING



FLANGE MOUNTING

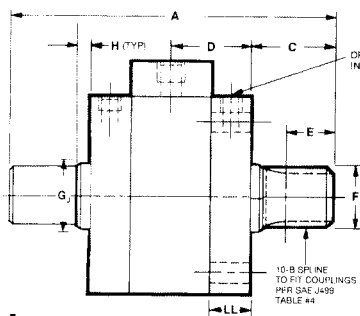

Journal Bearing Actuators

Standard MP actuators utilize a journal bearing made of an advanced composite material that is filament wound and PTFE lined. Additional precision engineered components include high performance seals for shaft, shoulder, vane and shoe.

NOTES: Connection of drains will add significant life to shaft seals. *This is highly recommended.*

See cut away view on page 34, page 52 for optional porting, pages 55 and 56 for optional manifolds and shaft couplings.

*NOTE: ON MPJ-116 & MPJ-128 USE END MOUNT DIMENSIONS

APPLICATION DATA

DIMENSIONS IN INCHES (METRIC)

	MPR-1x.4	MPR-1x1	MPJ-11	MPJ-22	MPJ-32	MPJ-34	MPJ-63	MPJ-84	MPJ-105	MPJ-116	MPJ-128
A	2.03 (51.6)	2.67 (67.8)	3.18 (81)	5.25 (133.4)	8.25 (210)	10.25 (260)	13.88 (352)	16.88 (429)	18.88 (480)	22.38 (568)	25.38 (645)
C	.63 (16)	.63 (16)	1.00 (25.40)	1.42 (36)	2.05 (52)	2.05 (52)	3.49 (88.6)	4.49 (114)	4.49 (114)	5.02 (127.5)	5.50 (140)
D	—	—	—	—	2.08 (52.8)	3.08 (78)	3.45 (87.6)	3.95 (100.3)	4.95 (125.7)	6.17 (156.7)	7.19 (182.6)
E	—	—	.54 (13.7)	.90 (22.9)	1.12 (28.5)	1.12 (28.5)	1.75 (44.5)	2.50 (63.5)	2.75 (69.8)	3.25 (82.6)	4.00 (101.6)
F*	—	—	.4997 (12.692)	.7497 (19.042)	1.2455 (31.636)	1.2455 (31.636)	1.9935 (50.635)	2.4935 (63.335)	2.9935 (76.035)	3.4935 (88.735)	3.9935 (101.435)
F₁	—	—	19T 40/80P 4750PD	29T 40/80P 7250PD	—	—	—	—	—	—	—
G	—	—	—	—	1.27 (32.26)	1.27 (32.26)	2.02 (51.3)	3.00 (76.2)	3.02 (76.7)	3.74 (95)	—
H	—	—	—	—	.30 (7.6)	.30 (7.6)	.49 (12)	.49 (12)	.49 (12)	.50 (12)	.09 (2.3)
J	—	—	—	—	3.25 (82.5)	5.25 (133.4)	5.50 (139.7)	6.00 (152.4)	7.00 (177.8)	9.50 (241.3)	11.25 (285.75)
K	—	—	—	—	.45 (11.4)	.45 (11.4)	.70 (17.8)	.95 (24)	1.45 (36.8)	1.44 (36.6)	1.56 (39.6)
L	—	—	—	—	—	—	—	—	—	—	—
M	—	—	—	—	—	—	—	—	—	—	—
N*	—	—	—	—	—	—	—	—	—	—	—
P	—	—	—	—	—	—	—	—	—	—	—
Q	—	—	—	—	—	—	—	—	—	—	—
R	—	—	—	—	—	—	—	—	—	—	—
S	—	—	—	—	—	—	—	—	—	—	—
T**	—	—	—	—	—	—	—	—	—	—	—
U	—	—	—	—	—	—	—	—	—	—	—
V	—	—	—	—	—	—	—	—	—	—	—
W	—	—	—	—	—	—	—	—	—	—	—
X	—	—	—	—	—	—	—	—	—	—	—
Y	—	—	—	—	—	—	—	—	—	—	—
Z	—	—	—	—	—	—	—	—	—	—	—
AA	—	—	—	—	—	—	—	—	—	—	—
BB	—	—	—	—	—	—	—	—	—	—	—
CC	—	—	—	—	—	—	—	—	—	—	—
CC₁	—	—	—	—	—	—	—	—	—	—	—
DD	—	—	—	—	—	—	—	—	—	—	—
EE	—	—	—	—	—	—	—	—	—	—	—
FF**	—	—	—	—	—	—	—	—	—	—	—
GG	—	—	—	—	—	—	—	—	—	—	—
HH	—	—	—	—	—	—	—	—	—	—	—
JJ	—	—	—	—	—	—	—	—	—	—	—
KK	—	—	—	—	—	—	—	—	—	—	—
LL	—	—	—	—	—	—	—	—	—	—	—
MM	—	—	—	—	—	—	—	—	—	—	—

*± .0005 in. (0.01 mm) **±.005 in. (0.13 mm)

NOTES:

*PER 270° MP-11 & MP-22

**PER 90°, MPR-1x.4, MPR-1x1, MP-11 & MP-22

750 PSI MAX. MPR-1x.4 & MPR-1x1

NOTE: See how to order on page 34.

PERFORMANCE

SINGLE VANE 280° ROTATION (±5°) *						
MODEL	TORQUE IN-LBS (N•m)			VOLUMETRIC DISPLACEMENT *IN ³ (cm ³)		APPROX. WEIGHT LB (Kg)
	100 PSI (6.9 BAR)	500 PSI (34.5 BAR)	1000 PSI (69.0 BAR)	PER 280°	PER RAD	
	MPJ-11	8 (.90)	56 (6.33)	117 (13.22)	.835 (13.69)	
MPJ-22	56 (6.33)	333 (37.63)	679 (76.73)	3.82 (62.61)	.815 (13.36)	3 (1.36)
MPJ-32	103 (11.64)	705 (79.67)	1595 (180.24)	9.2 (150.79)	1.88 (30.81)	19 (8.6)
MPJ-34	206 (23.28)	1410 (159.33)	3190 (360.47)	18.4 (301.58)	3.76 (61.31)	26 (11.8)
MPJ-63	600 (67.80)	4090 (462.17)	9280 (1048.64)	53.30 (873.59)	10.90 (179)	122 (55.2)
MPJ-84	1430 (161.59)	9750 (1101.75)	22100 (2497.30)	127.40 (2088.09)	26.07 (428)	203 (92.1)
MPJ-105	2850 (322.05)	19400 (2192.20)	44000 (4972)	253.3 (4151.59)	51.83 (850)	348 (157.9)
MPJ-116	4650 (525.45)	31700 (3582)	71800 (8113)	412.9 (6767.43)	84.50 (1386)	552 (250.4)
MPJ-128	6625 (748.63)	45151 (5102)	102345 (11565)	588.4 (9643.88)	120.41 (1975)	835 (378.8)

FOR 1500 PSI (103.4 BAR) CONTACT PLANT.

DOUBLE VANE 100° ROTATION (±5°) **						
MODEL	TORQUE IN-LBS (N•m)			VOLUMETRIC DISPLACEMENT **IN ³ (cm ³)		APPROX. WEIGHT LB (Kg)
	100 PSI (6.9 BAR)	500 PSI (34.5 BAR)	1000 PSI (69.0 BAR)	PER 100°	PER RAD	
	MPR-1x.4	2 (.23)	20 (2.26)	31 (3.50)	.093 (1.52)	
MPR-1x1	5 (.57)	54 (6.10)	85 (9.60)	.258 (4.23)	.164 (2.69)	.32 (.14)
MPJ-11	23 (2.60)	156 (17.63)	322 (36.39)	.557 (9.13)	.357 (5.85)	.84 (.38)
MPJ-22	121 (13.67)	728 (82.26)	1487 (168.03)	2.56 (41.96)	1.63 (26.72)	3.2 (1.45)
MPJ-32	225 (25.43)	1540 (174)	3380 (381.94)	6.60 (108.17)	3.78 (62)	20 (9.1)
MPJ-34	450 (50.85)	3080 (348.04)	6750 (762.75)	13.00 (213.07)	7.44 (122)	27 (12.2)
MPJ-63	1310 (148.03)	8950 (1011.35)	19600 (2214.80)	38.0 (622.82)	21.77 (357)	126 (57.2)
MPJ-84	3120 (352.56)	21350 (2412.55)	46700 (5277.00)	91.0 (1491.49)	52.14 (855)	212 (96.2)
MPJ-105	6220 (702.86)	42500 (4802.50)	93300 (10542.90)	181.0 (2966.59)	103.7 (1700)	364 (165.1)
MPJ-116	10100 (1141.30)	69300 (7831)	152100 (17187)	295.0 (4835.05)	169.0 (2772)	581 (263.5)
MPJ-128	14450 (1633)	98735 (11157)	216730 (24490)	420.3 (6888.72)	240.8 (3950)	875 (396.9)

FOR 1500 PSI (103.4 BAR) CONTACT PLANT.

TEST PARAMETERS — OIL			
MODEL	MAX BREAK IN PSI (BAR) OIL	BY-PASS LEAKAGE MAX ALLOWABLE	
		CUBIC IN. PER MIN. AT 1000 PSI (69.0 BAR) OIL	
		1V	2V
MPR-1x.4	50 (3.4)	—	3.5
MPR-1x1	50 (3.4)	—	3.5
MPJ-11	60 (4.14)	9	9
MPJ-22	60 (4.14)	11	11
MPJ-32	50 (3.45)	12	12
MPJ-34	50 (3.45)	12	12
MPJ-63	50 (3.45)	13	13
MPJ-84	40 (2.8)	14	14
MPJ-105	40 (2.8)	15	15
MPJ-116	40 (2.8)	16	16
MPJ-128	40 (2.8)	17	17

WHEN REFERENCING SHADED AREAS SEE
NOTES ON BOTTOM OF THIS PAGE.

MPR-1 x .4

FOR SERVICE DETAILS CONSULT FACTORY

MPR-1 x 1

FOR SERVICE DETAILS CONSULT FACTORY

MPJ-11

FOR SERVICE DETAILS CONSULT FACTORY

MPJ-22

FOR SERVICE DETAILS CONSULT FACTORY

MPJ

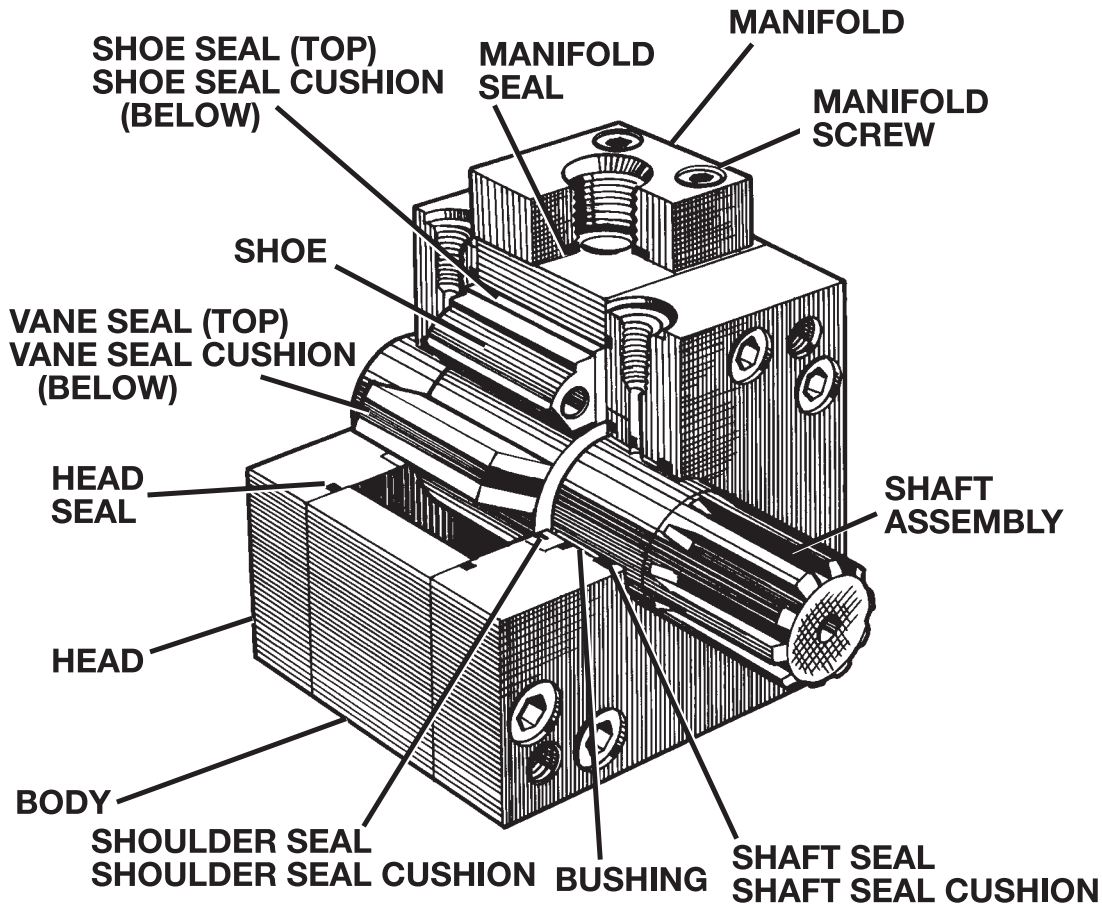

HOW TO ORDER

Sample: **MPJ 128 2V DE K BASE OIL**

Model _____	Fluid Medium
MPJ	Oil, Air,
Size _____	Other
Number of Vanes _____	Mounting
1V—Single Vane	End-Base, Foot,
2V—Double Vane	Flange, Special
Shaft Extension _____	Shaft Type
SE—Single Extension	SS—10-B Spline
DE—Double Extension	ISER—45° Involute Serration
	(MPJ-11 & MPJ-22 only)
	K—Keyed
	Z—Special

If you require a special shaft extension, special mounting, air bleeds, special rotation control, or other special requirements, please enclose a drawing showing these requirements.



Micromatic

HIGH PRESSURE

7 Standard Sizes

3,000 PSI

Up to 696,000 in/lbs of Torque

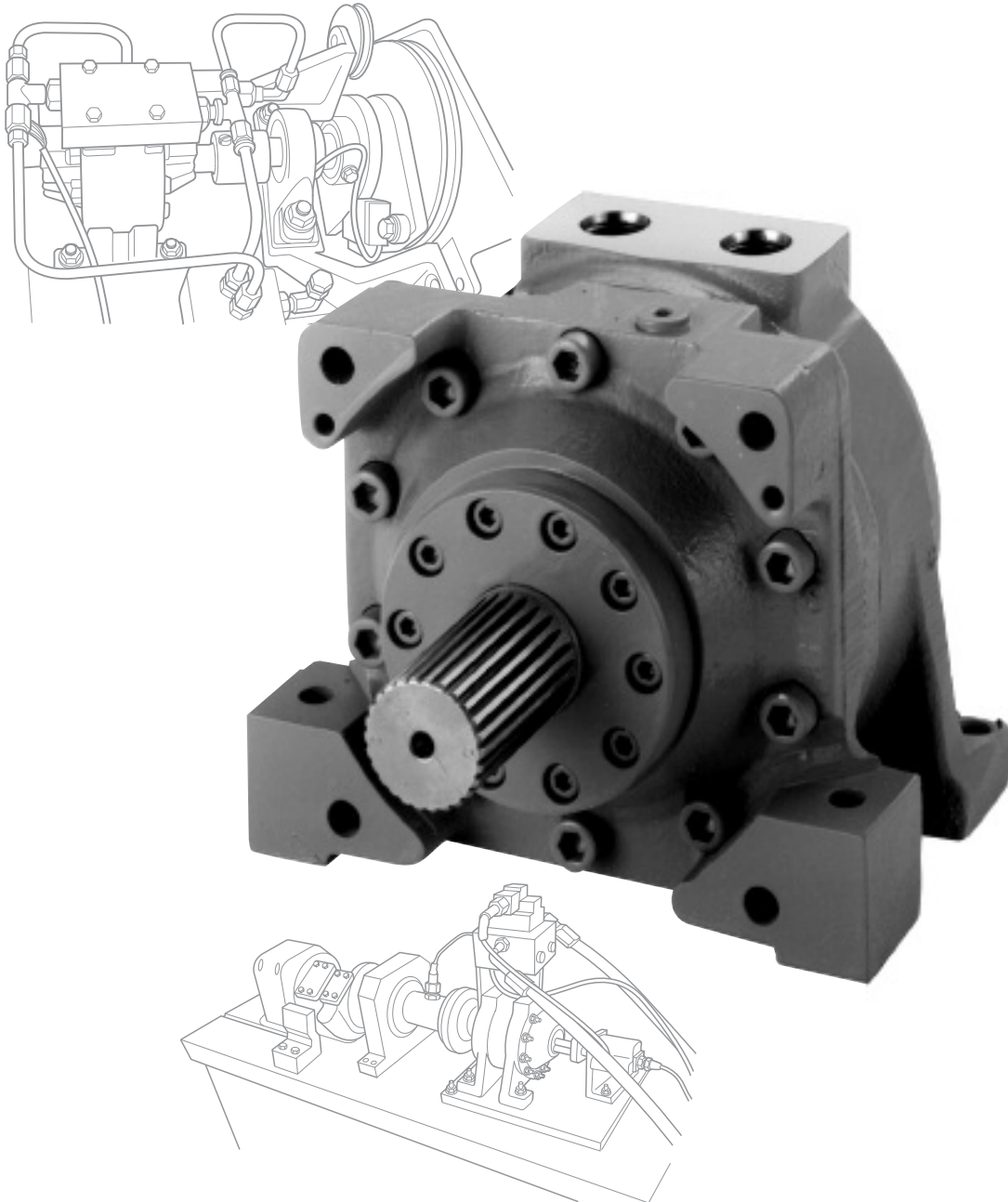

PROVIDING the “**MUSCLE**” for your lifting, turning, indexing, opening, closing, clamping, mixing, bending, testing, steering. . . **applications.**

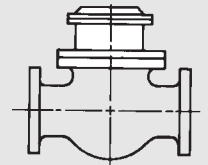

VALVE OPEN—CLOSE

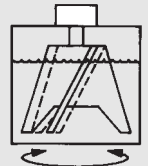

MIX—STIR

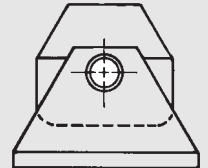

TURNOVER—DUMP

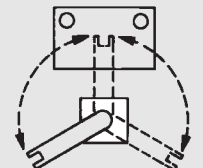

LOAD—POSITION—UNLOAD

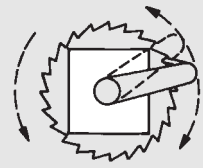

CONTINUOUS ROTATION

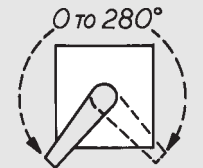

TURN—OSCILLATE

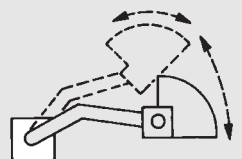

MATERIAL HANDLING

26R MODELS

**HIGH PRESSURE *1
3000 PSI MAX**

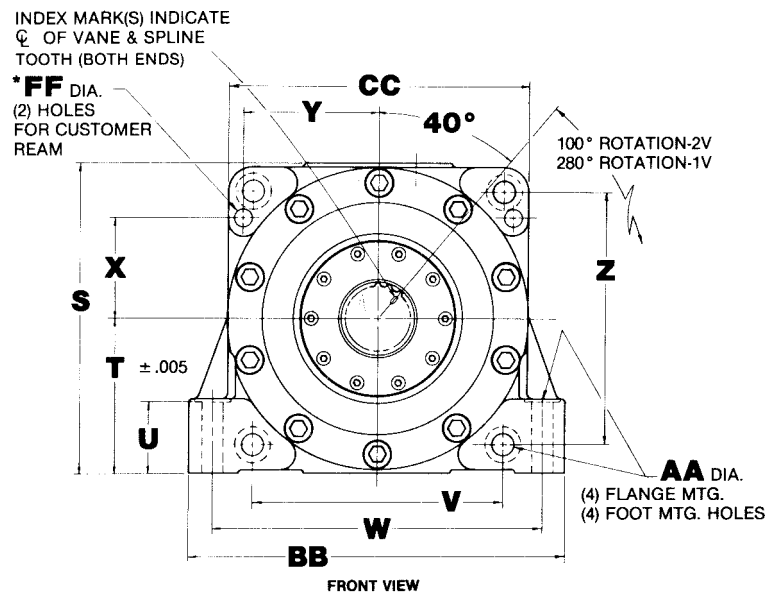
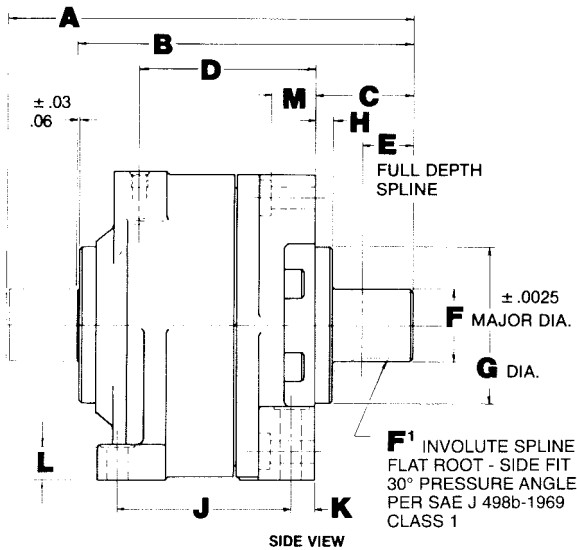
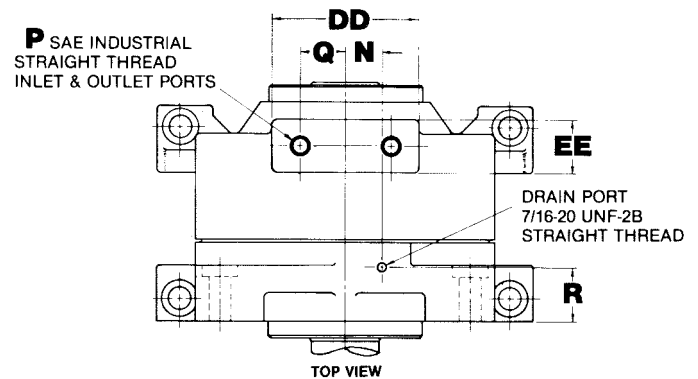

NOTE: Connection of drains will add significant life to shaft seals. *Their use is highly recommended.*

***NOTE:** FOR FLANGE MTD. UNITS THESE HOLES SHOULD BE TRANSFER DRILLED AND REAMED AT INSTALLATION FOR INSERTION OF DOWEL PINS. (THIS WILL AID IN PREVENTING "RACKING" OF ACTUATOR ON MOUNTING BOLTS DUE TO TORSIONAL FORCES)

***1 2000 PSI maximum is recommended for severe duty applications, such as operating at maximum torque at high cycle rates for extended periods. Please consult factory for applications beyond 2000 PSI. 3000 PSI can be used on intermittent shockless actuations.**

NOTE: See cut away view on page 38.

NOTE: See pages 55 and 56 for optional manifolds and shaft couplings.

APPLICATION DATA

DIMENSIONS IN INCHES (METRIC)

	26R-2	26R-5	26R-10	26R-17	26R-31	26R-62	26R-124
A	10.08 (256)	12.06 (306.3)	14.19 (360.4)	16.57 (420.9)	18.58 (471.9)	24.38 (619.3)	31.22 (792.9)
B	8.02 (203.7)	9.84 (249.9)	11.50 (292.1)	13.51 (343.2)	15.01 (381.3)	19.44 (493.8)	25.06 (636.5)
C	2.62 (66.5)	2.86 (72.6)	3.41 (86.6)	3.87 (98.3)	4.38 (111.3)	6.02 (152.9)	7.51 (190.8)
D	3.50 (88.9)	4.86 (123.4)	5.63 (143)	6.61 (167.9)	7.80 (198.1)	9.87 (250.7)	12.80 (325.1)
E	1.62 (41.1)	1.75 (44.4)	2.12 (53.8)	2.50 (63.5)	3.00 (76.2)	4.25 (107.9)	5.25 (133.4)
F*	1.3335 (33.871)	1.6685 (42.380)	2.2268 (56.561)	2.6735 (67.907)	3.2735 (83.147)	4.0935 (103.975)	4.8435 (123.025)
F'	26T (20/40P)	26T (16/32P)	26T (12/24P)	26T (10/20P)	32T (10/20P)	32T (8/16P)	38T (8/16P)
G	1.3000PD (3.8)	1.6250PD (4.25)	2.1667PD (5.0)	2.6000PD (6.0)	3.2000PD (7.0)	4.0000PD (9.13)	4.7500PD (10.5)
H	3.38 (85.9)	4.25 (108)	5.00 (127)	6.00 (152.4)	7.00 (177.8)	9.13 (231.9)	10.50 (266.7)
J	.50 (12.7)	.57 (14.5)	.64 (16.3)	.76 (19.3)	.76 (19.3)	1.02 (25.9)	1.27 (32.3)
K	3.56 (90.4)	4.62 (117.3)	5.37 (136.4)	6.69 (169.9)	7.75 (196.9)	9.31 (236.5)	12.19 (309.6)
L	.63 (16)	.86 (21.8)	1.01 (25.7)	1.07 (27.2)	1.04 (26.4)	1.51 (38.4)	2.01 (51.1)
M	.56 (14.2)	.81 (20.6)	.94 (23.9)	1.12 (28.4)	1.50 (38.10)	1.69 (42.9)	2.06 (52.3)
N	.75 (19.1)	1.25 (31.8)	1.50 (38.1)	1.75 (44.5)	2.00 (50.8)	2.68 (68.1)	4.00 (101.6)
P	.77 (19.6)	1.01 (25.7)	1.19 (30.2)	1.47 (37.3)	1.68 (42.7)	2.17 (55.1)	2.44 (62)
Q	3/4-16 (.88)	3/4-16 (1.06)	7/8-14 (1.25)	1 1/16-12 (1.62)	1 1/8-12 (2.06)	1 1/2-12 (2.62)	1 3/8-12 (2.75)
R	.88 (22.4)	1.06 (26.9)	1.25 (31.8)	1.62 (41.1)	2.06 (52.3)	2.62 (66.5)	2.75 (69.9)
S	1.29 (32.8)	1.80 (45.7)	1.82 (46.2)	2.17 (55.1)	2.42 (61.5)	2.79 (70.9)	3.67 (93.2)
T**	6.00 (152.4)	8.00 (203.2)	9.76 (247.9)	11.26 (286)	13.76 (349.5)	17.13 (435.1)	20.50 (520.7)
U	3.00 (76.20)	4.00 (101.60)	4.875 (123.83)	5.625 (142.88)	6.875 (174.63)	8.562 (217.47)	10.25 (260.35)
V	1.50 (38.1)	1.94 (49.3)	2.25 (57.2)	2.62 (66.5)	3.19 (81.0)	3.90 (99.1)	4.88 (123.9)
W	4.88 (123.9)	6.38 (162.1)	8.00 (203.2)	9.25 (234.9)	11.25 (285.8)	14.00 (355.6)	16.75 (425.5)
X	6.25 (158.8)	8.25 (209.6)	10.25 (260.4)	11.87 (301.5)	14.87 (377.7)	18.37 (466.6)	21.25 (539.8)
Y	1.78 (45.2)	2.44 (61.9)	2.94 (74.7)	3.50 (88.9)	4.44 (112.8)	5.44 (138.2)	6.31 (160.3)
Z	2.61 (66.3)	3.41 (86.6)	4.28 (108.7)	4.94 (125.5)	6.06 (153.9)	7.44 (188.9)	8.81 (223.8)
AA	4.88 (123.9)	6.38 (162.1)	8.00 (203.2)	9.25 (234.9)	11.25 (285.8)	14.00 (355.6)	16.75 (425.5)
BB	.41 (10.4)	.53 (13.5)	.69 (17.5)	.81 (20.6)	.94 (23.9)	1.06 (26.9)	1.31 (33.3)
CC	7.12 (180.8)	9.62 (244.3)	11.75 (298.5)	13.62 (345.9)	17.00 (431.8)	21.00 (533.4)	24.50 (622.3)
DD	5.75 (146.1)	7.62 (193.5)	9.50 (241.3)	11.00 (279.4)	13.50 (342.9)	16.75 (425.5)	19.75 (501.7)
EE	3.38 (85.85)	3.94 (100.1)	4.50 (114.3)	5.75 (146.1)	6.62 (168.1)	8.00 (203.2)	9.62 (244.3)
FF	1.62 (41.1)	1.81 (45.9)	2.00 (50.8)	2.50 (63.5)	2.50 (63.5)	2.75 (69.9)	4.12 (104.6)
	.23 (5.8)	.34 (8.6)	.47 (11.9)	.72 (18.3)	.84 (21.3)	.84 (21.3)	.84 (21.3)

*± .0025 in. (0.064 mm)

** .005 in. (0.13 mm)

PERFORMANCE

SINGLE VANE 280° ROTATION (±1°)						
MODEL	TORQUE IN-LBS (N•m)			VOLUMETRIC DISPLACEMENT IN ³ (cm ³)		APPROX. WEIGHT LB (Kg)
	1000 PSI (69.0 BAR)	2000 PSI (137.9 BAR)	3000 PSI (206.9 BAR)	PER 280°	PER RAD	
	26R2	1720 (194.4)	3440 (388.7)	5160 (583.1)	9.35 (153.25)	
26R5	3900 (440.7)	7800 (881.4)	11700 (1322.1)	21.20 (347.47)	4.34 (71.13)	67 (30)
26R10	9100 (1028.5)	18200 (2056.6)	27300 (3084.9)	49.50 (811.31)	10.12 (165.87)	115 (52)
26R17	15200 (1717.6)	30400 (3435.2)	45600 (5152.8)	82.60 (1353.81)	16.90 (276.99)	207 (94)
26R31	27500 (3107.5)	55000 (6215)	82500 (9322.5)	149.50 (2450.31)	30.60 (501.55)	334 (152)
26R62	56000 (6328)	112000 (12656)	168000 (18984)	304.00 (4982.56)	62.20 (1019.46)	680 (308)
26R124	110000 (12430)	220000 (24860)	330000 (37290)	598.00 (9801.22)	122.00 (1999.58)	1221 (554)

DOUBLE VANE 100° ROTATION (±1°)						
MODEL	TORQUE IN-LBS (N•m)			VOLUMETRIC DISPLACEMENT IN ³ (cm ³)		APPROX. WEIGHT LB (Kg)
	1000 PSI (69.0 BAR)	2000 PSI (137.9 BAR)	3000 PSI (206.9 BAR)	PER 100°	PER RAD	
	26R2	3650 (412.5)	7300 (824.9)	10950 (1237.4)	6.67 (109.32)	
26R5	8240 (931)	16480 (1858.9)	24720 (2791.1)	15.10 (247.49)	8.68 (142.27)	70 (32)
26R10	19300 (2180.9)	38600 (4361.8)	57900 (6542.7)	35.40 (580.21)	20.24 (331.73)	124 (56)
26R17	32200 (3638.6)	64400 (7277.2)	96600 (10915.8)	59.00 (967.01)	33.80 (553.98)	225 (102)
26R31	58300 (6587.9)	116600 (13175.8)	174900 (19763.7)	106.80 (1750.45)	61.20 (1003.07)	363 (165)
26R62	118500 (13390.5)	237000 (26781)	355500 (40171.5)	217.00 (3556.63)	124.40 (2038.92)	730 (331)
26R124	232000 (26216)	464000 (52432)	696000 (78648)	427.00 (6998.53)	244.00 (3999.16)	1318 (598)

TEST PARAMETERS — OIL					
MODEL	MAX BREAK IN PSI (BAR)	BY-PASS LEAKAGE-MAX ALLOWABLE			
		CUBIC IN. PER MIN. AT 3000 PSI		CUBIC CM. PER MIN. AT 3000 PSI	
		1V	2V	1V	2V
26R2	150 (10.3)	6	8	98.3	131.1
26R5	140 (9.6)	6	8	98.3	131.1
26R10	130 (8.9)	8	10	131.1	163.9
26R17	120 (8.3)	8	10	131.1	163.9
26R31	110 (7.6)	10	12	163.9	196.7
26R62	100 (6.9)	10	12	163.9	196.7
26R124	90 (6.2)	12	15	196.7	245.9

NOTE: See how to order on page 38.

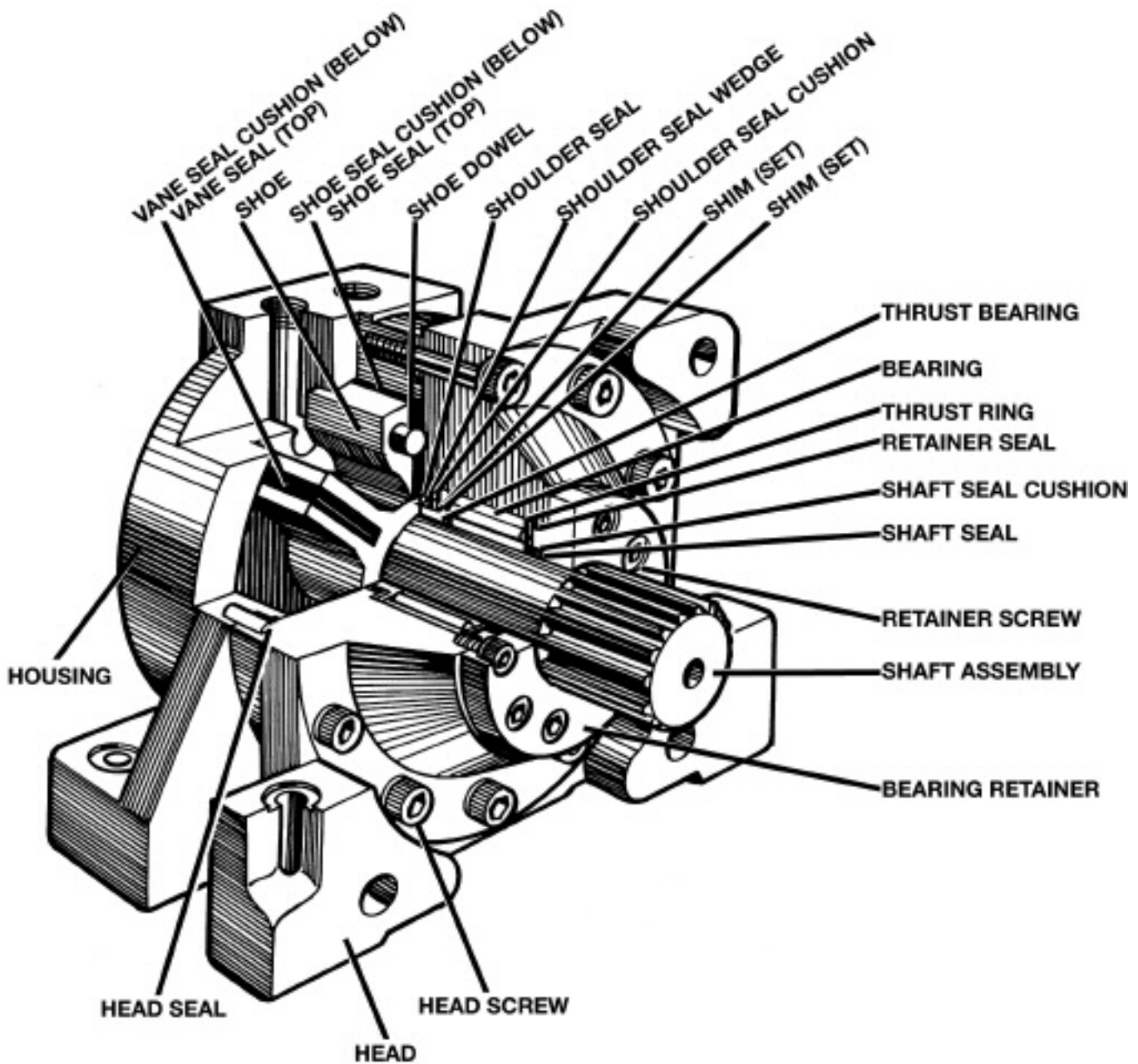

HOW TO ORDER

Sample: 26R 62 2V DE IS FT./FLG. OIL

Model _____

Size _____

Number of Vanes _____

1V—Single Vane

2V—Double Vane

Shaft Extension _____

SE—Single Extension

DE—Double Extension

_____ **Fluid Medium**

Oil, Other

_____ **Mounting**

Foot/Flange

Special

_____ **Shaft Type**

IS—30° Involute Spline

Z—Special

If you require a special shaft extension, special mounting, air bleeds, special rotation control, or other special requirements, please enclose a drawing showing these requirements. Each number and letter has a specific meaning as shown in the sample.



Micromatic

HIGH PRESSURE

10 Standard Sizes

3,000 PSI

Up to 741,000 in/lbs of Torque

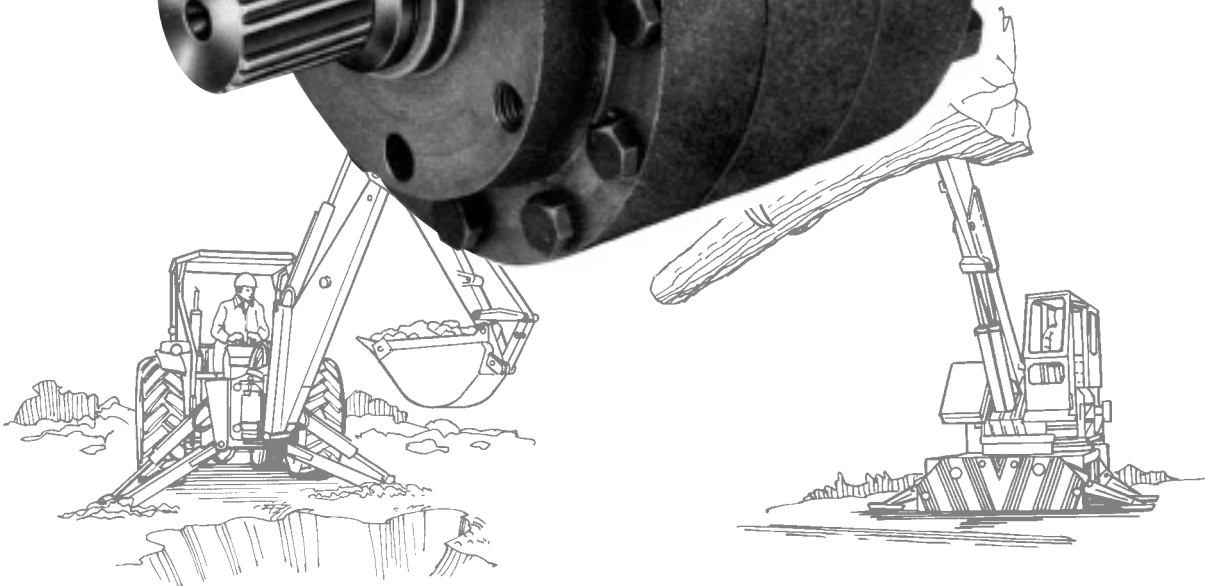
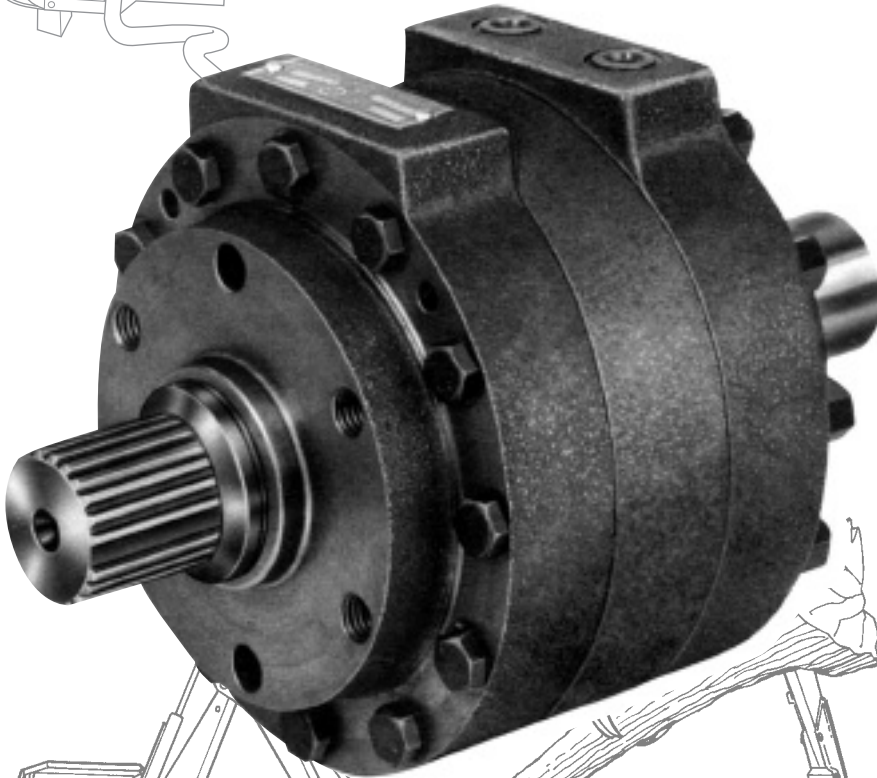
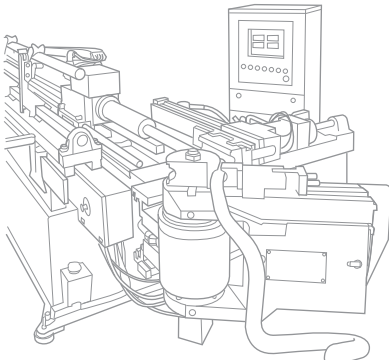

PROVIDING the “**MUSCLE**” for your lifting, turning, indexing, opening, closing, clamping, mixing, bending, testing, steering... **applications.**

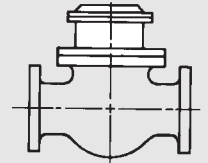

VALVE OPEN—CLOSE

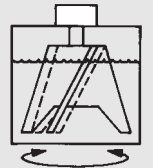

MIX—STIR

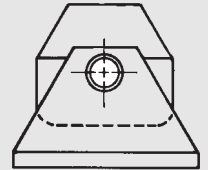

TURNOVER—DUMP

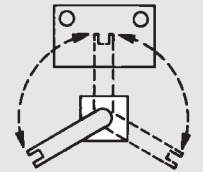

LOAD—POSITION—UNLOAD

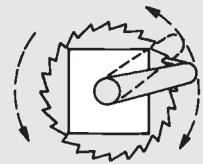

CONTINUOUS ROTATION



TURN—OSCILLATE

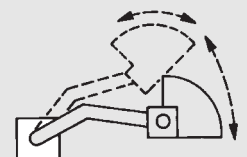

MATERIAL HANDLING

SS MODELS

HIGH PRESSURE *1
3000 PSI MAX

BASE MOUNTING SS-2A & SS-5A

For larger aluminum units, please consult factory.

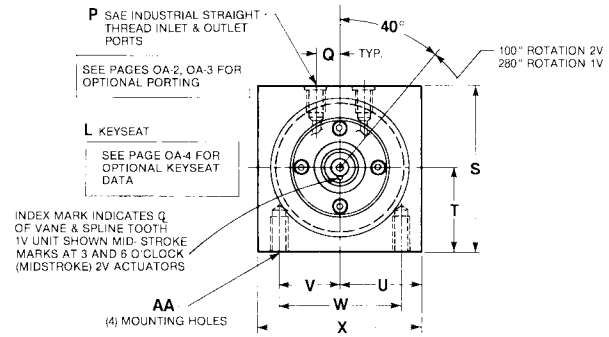
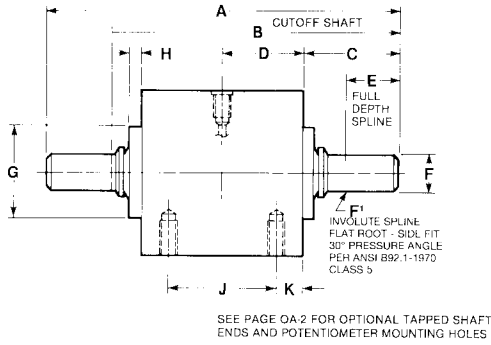

END MOUNTING SS-2A & SS-5A

For larger aluminum units, please consult factory.

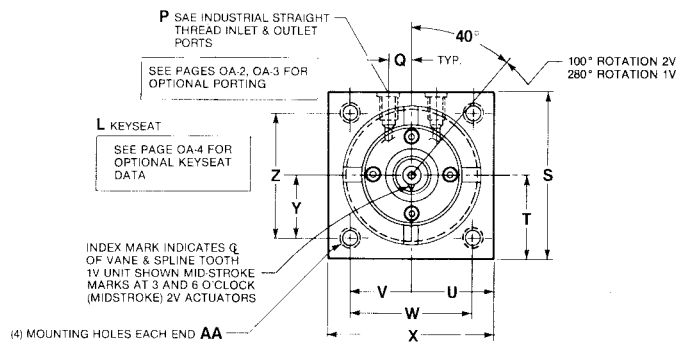
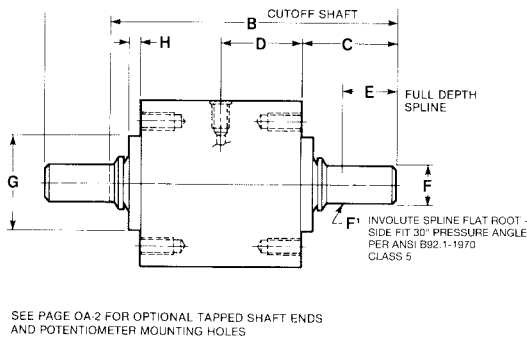

END MOUNTING SS-1 THRU SS-130

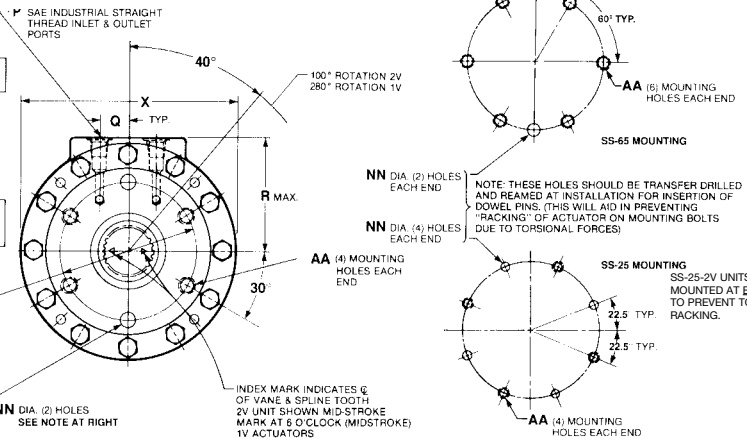
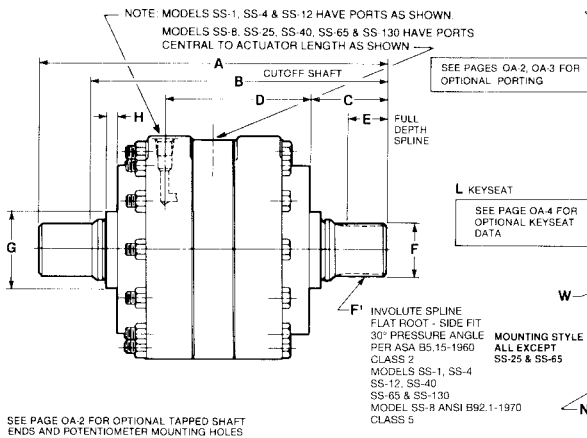

FOOT MOUNTING SS-1 THRU SS-130

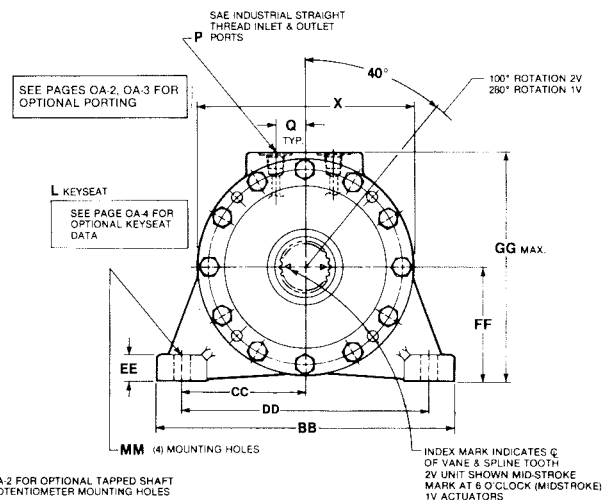
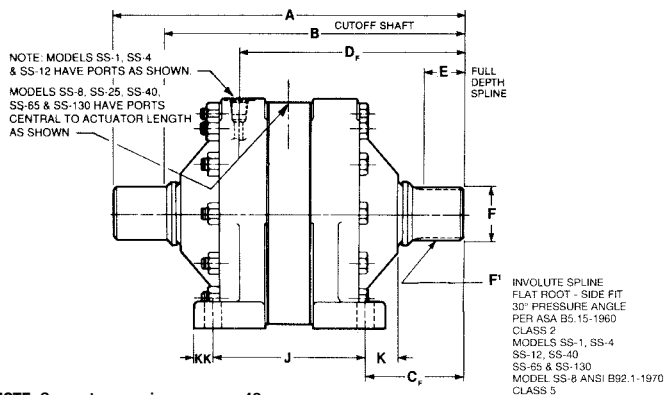

NOTE: See cut away view on page 42

NOTE: See pages 55 and 56 for optional manifolds and shaft couplings.

SEE PAGE OA-2 FOR OPTIONAL TAPPED SHAFT ENDS AND POTENTIOMETER MOUNTING HOLES

APPLICATION DATA

DIMENSIONS IN INCHES (METRIC)

	SS-2A	SS-5A	SS-1	SS-4	SS-8	SS-12	SS-25	SS-40	SS-65	SS-130
A	5.00 (127.0)	6.50 (165.10)	7.66 (194.56)	10.50 (266.70)	11.69 (296.92)	14.12 (358.90)	21.28 (540.51)	20.06 (509.52)	23.75 (603.25)	29.75 (755.65)
B	3.89 (98.81)	5.05 (128.27)	6.91 (175.51)	9.05 (229.87)	9.85 (250.19)	11.94 (303.28)	17.06 (433.32)	16.35 (415.29)	19.75 (501.65)	23.50 (596.9)
C	1.38 (35.05)	1.75 (44.45)	1.38 (35.05)	2.34 (59.43)	3.28 (83.31)	3.31 (84.07)	5.81 (147.57)	5.06 (128.52)	6.26 (159.00)	8.12 (206.25)
C_F	—	—	2.19 (55.63)	2.94 (74.68)	3.28 (83.31)	4.00 (101.60)	5.52 (140.21)	5.38 (136.65)	6.26 (159.00)	8.75 (222.25)
D	1.13 (28.70)	1.50 (38.10)	3.35 (85.09)	4.40 (111.76)	3.00 (76.2)	5.75 (146.05)	4.81 (122.17)	4.96 (125.98)	6.38 (162.05)	6.75 (171.45)
D_F	—	—	4.69 (119.13)	6.75 (171.45)	5.64 (143.34)	9.06 (230.12)	10.64 (270.26)	10.03 (254.76)	11.95 (303.53)	14.87 (377.70)
E	.90 (22.86)	1.10 (27.94)	.59 (14.98)	1.22 (30.98)	1.75 (44.45)	1.89 (48.00)	3.27 (83.05)	3.27 (83.06)	3.88 (98.55)	5.50 (139.70)
E[*]	.5935 (15.075)	.7145 (18.148)	1.0355 (26.302)	1.5452 (39.249)	1.9362 (49.181)	2.1962 (55.785)	3.3445 (84.950)	3.3445 (84.950)	3.8435 (97.625)	5.2935 (134.455)
F[†]	18T 32/64P 5625PD	22T 32/64P 5875PD	20T 20/40P 1.000PD	24T 16/32P 1.500PD	30T 16/32P 1.875PD	26T 12/24P 2.1667PD	26T 8/16P 3.2500PD	26T 8/16P 3.2500PD	30T 8/16P 3.7500PD	31T 8/12P 5.1667PD
G	1.44 (36.57)	1.70 (43.18)	1.63 (41.40)	2.25 (57.15)	3.25 (82.55)	3.25 (82.55)	6.00 (152.40)	4.75 (120.65)	6.50 (165.10)	10.25 (260.35)
H	.27 (6.86)	.22 (5.58)	.13 (3.30)	.34 (8.64)	.44 (11.18)	.56 (14.22)	1.38 (35.05)	.69 (17.53)	.75 (19.05)	1.13 (28.70)
J	1.75 (44.45)	2.00 (50.80)	3.27 (83.06)	4.62 (117.35)	5.12 (130.05)	6.12 (155.45)	10.25 (260.35)	9.3 (236.22)	11.38 (289.05)	12.25 (311.15)
K	.25 (6.35)	.50 (12.70)	.94 (23.88)	.94 (23.88)	.87 (22.10)	1.25 (31.75)	1.07 (27.18)	1.00 (25.4)	1.44 (36.58)	1.75 (44.45)
L	1/8 x 1/16 (3.17 x 1.58)	3/16 x 3/32 (4.76 x 2.38)	1/4 x 1/8 (6.35 x 3.17)	3/8 x 3/16 (9.52 x 4.76)	1/2 x 1/4 (12.70 x 6.35)	5/8 x 3/8 (15.88 x 9.52)	3/4 x 3/8 (19.05 x 9.52)	1 x 1/2 (25.4 x 12.70)	1 1/4 x 3/8 (31.75 x 15.87)	—
P	.75 (19.05)	.70 (17.78)	.75 (19.05)	1.25 (31.75)	1.88 (47.53)	2.00 (50.80)	3.25 (82.55)	3.25 (82.55)	3.88 (98.55)	5.50 (139.70)
Q	.375 (9.53)	.438 (11.12)	.50 (12.70)	.88 (22.35)	1.12 (28.45)	1.25 (31.75)	1.78 (45.21)	1.88 (47.75)	2.13 (54.10)	2.75 (69.85)
R	—	—	2.62 (66.55)	3.53 (89.66)	4.25 (107.95)	4.81 (122.17)	5.53 (140.46)	7.00 (177.80)	7.75 (196.85)	10.12 (257.05)
S	2.25 (57.15)	3.00 (76.20)	—	—	—	—	—	—	—	—
T	1.13 (28.70)	1.50 (38.10)	—	—	—	—	—	—	—	—
U	1.13 (28.70)	1.50 (38.10)	—	—	—	—	—	—	—	—
V	.88 (22.35)	1.13 (28.70)	—	—	—	—	—	—	—	—
W	1.75 (44.45)	2.25 (57.15)	2.63 (66.80)	4.13 (104.90)	5.00 (127.00)	5.63 (143.00)	9.00 (228.60)	8.75 (222.25)	9.00 (228.60)	13.50 (342.90)
X	2.25 (57.15)	3.00 (76.2)	4.88 (123.95)	6.65 (168.91)	8.41 (213.61)	9.15 (232.41)	10.44 (265.18)	13.50 (342.90)	15.00 (381.00)	20.00 (508.00)
Y	.88 (22.35)	1.13 (28.70)	—	—	—	—	—	—	—	—
Z	1.75 (44.45)	2.25 (57.15)	—	—	—	—	—	—	—	—
AA	1/4-20 31DP (7.87)	3/8-18 .62DP (15.75)	1/2-16 .75DP (19.05)	5/8-13 1.0DP (25.40)	3/4-11 1.0DP (25.40)	7/8-11 1.25DP (31.75)	1-11 1.25DP (31.75)	1 1/8-10 1.50DP (38.10)	1 1/2-10 1.25DP (31.75)	1-8 2.0DP (50.80)
BB	—	—	6.50 (165.10)	9.00 (228.60)	11.00 (279.40)	11.88 (301.75)	13.00 (330.20)	15.25 (387.35)	19.00 (482.60)	25.25 (641.35)
CC	—	—	2.75 (69.85)	3.75 (95.25)	4.75 (120.65)	5.06 (128.52)	5.00 (127.00)	6.50 (165.10)	8.00 (203.20)	11.00 (279.40)
DD	—	—	5.50 (139.70)	7.50 (190.50)	9.50 (241.30)	10.13 (257.30)	10.00 (254.00)	13.00 (330.20)	16.00 (405.40)	22.00 (558.80)
EE	—	—	.63 (16.00)	.75 (19.05)	.94 (23.88)	.94 (23.88)	1.25 (31.75)	1.13 (28.70)	1.69 (42.93)	1.50 (38.10)
FF^{**}	—	—	2.50 (63.50)	3.38 (85.85)	4.375 (111.13)	4.63 (117.60)	5.38 (136.65)	6.88 (174.75)	7.875 (200.03)	10.13 (257.30)
GG	—	—	5.13 (130.30)	6.91 (175.51)	8.63 (219.20)	9.44 (239.78)	10.75 (273.05)	13.75 (349.25)	15.63 (397.00)	20.25 (514.35)
KK	—	—	.50 (12.70)	.63 (16.00)	.91 (23.11)	.88 (22.35)	1.07 (27.18)	1.00 (25.40)	1.44 (36.58)	1.62 (41.11)
MM	—	—	.41 (10.41)	.53 (13.46)	.69 (17.53)	.78 (19.81)	.97 (23.88)	1.31 (26.92)	1.31 (33.27)	1.56 (39.62)
NN^{***}	—	—	.41 (10.41)	.47 (11.94)	.47 (11.94)	.59 (14.98)	.62 (15.75)	.84 (21.3)	.84 (21.3)	1.22 (30.99)
	—	—	.75DP (19.05)	.75DP (19.05)	.75DP (19.05)	1.25DP (31.75)	1.25DP (31.75)	1.75DP (44.45)	1.50DP (38.10)	2.00DP (50.80)

* ± .0005 in. (0.013 mm) SS-2A, SS-5A, SS-1 ± .00075 in. (0.019 mm) SS-4, SS-8, SS-12 ± .0015 in. (0.038 mm) SS-25, SS-40

** ± .0025 in. (0.064 mm) SS-65, SS-130

*** ± .005 (.013 mm)

†† Model SS-25 has (4) holes on a 90° pattern rotated 22 1/2° counter-clockwise

*1 2000 PSI maximum is recommended for severe duty applications, such as operating at maximum torque at high cycle rates for extended periods. Please consult factory for applications beyond 2000 PSI.

NOTE: See how to order on page 42.

PERFORMANCE

MODEL	TORQUE IN-LBS (N•m)			VOLUMETRIC DISPLACEMENT IN ³ (CM ³)		APPROX. WEIGHT LB (Kg)
	1000 PSI (69.0 BAR)	2000 PSI (137.9 BAR)	3000 PSI (206.9 BAR)	PER 280°	PER RAD	
	SINGLE VANE 280° ROTATION (±5°)					
SS-2A	170 (19)	340 (38)	510 (58)	.95 (15.57)	.2 (3.27)	1.6 (.73)
SS-5A	380 (43)	760 (86)	—	2.18 (35.73)	.45 (7.37)	3.0 (1.36)
SS-1	1080 (122)	2160 (244)	3240 (366)	5.85 (95.88)	1.20 (19.66)	21.5 (9.75)
SS-4	3430 (388)	6860 (775)	10300 (1164)	18.59 (304.69)	3.81 (62.44)	48.5 (23)
SS-8	7200 (814)	14400 (1627)	21600 (2440)	39.04 (639.86)	8.00 (131.12)	78 (35)
SS-12	11210 (1266)	22420 (2533)	33615 (3798)	60.75 (995.69)	12.45 (204.05)	121.5 (55)
SS-25	22410 (2532)	44820 (5065)	67230 (7597)	121.51 (1991.54)	24.90 (408.11)	220 (100)
SS-40	36000 (4068)	72000 (8136)	108000 (12204)	195.20 (3199.32)	40.00 (655.60)	355 (161)
SS-65	58500 (6611)	117000 (13221)	175500 (19831)	317.20 (5198.90)	65.00 (1065.35)	560 (254)
SS-130	117000 (13221)	234000 (26442)	351000 (39663)	634.40 (10397.81)	130 (2130.70)	975 (442)

MODEL	TORQUE IN-LBS (N•m)			VOLUMETRIC DISPLACEMENT IN ³ (CM ³)		APPROX. WEIGHT LB (Kg)
	1000 PSI (69.0 BAR)	2000 PSI (137.9 BAR)	3000 PSI (206.9 BAR)	PER 100°	PER RAD	
	DOUBLE VANE 100° ROTATION (±5°)					
SS-2A	—	—	—	—	—	—
SS-5A	810 (91)	1620 (183)	—	1.57 (25.73)	.90 (14.75)	3.2 (1.45)
SS-1	2280 (257)	4560 (515)	6840 (773)	4.18 (68.51)	2.40 (39.33)	22 (10)
SS-4	7230 (817)	14460 (1634)	21700 (2452)	13.29 (217.82)	7.62 (124.89)	50 (23)
SS-8	15200 (1718)	30400 (3435)	45600 (5153)	27.92 (457.60)	16 (262.24)	80 (36.29)
SS-12	23660 (2673)	47320 (5347)	70965 (8019)	43.45 (712.14)	24.90 (408.11)	125 (57)
SS-25	47310 (5346)	94620 (10692)	141930 (16038)	86.41 (1416.31)	49.80 (816.22)	230 (104)
SS-40	76000 (8588)	152000 (17176)	228000 (25764)	139.61 (2288)	80.00 (1311)	370 (168)
SS-65	123500 (13955)	247000 (27911)	370500 (41866)	226.87 (3718)	130 (2130)	582 (264)
SS-130	247000 (27911)	494000 (55822)	741000 (83733)	453.75 (7436)	260 (4261)	1035 (469)

MODEL	MAX BREAK IN PSI (BAR)	BY-PASS LEAKAGE—MAX ALLOWABLE		
		CUBIC IN. PER MIN. AT 3000 PSI (206.9 BAR)	CUBIC CM. PER MIN. AT 3000 PSI (206.9 BAR)	
		1V	1V 2V	
SS-2A	125 (8.6)	10	200	N/A
††SS-5A	125 (8.6)	12	180	200
SS-1	100 (6.90)	14	229	295
SS-4	50 (3.44)	16	262	370
SS-8	50 (3.44)	18	295	N/A
SS-12	50 (3.44)	20	328	470
SS-25	50 (3.44)	22	360	N/A
SS-40	50 (3.44)	25	410	1080
SS-65	50 (3.44)	28	459	1370
SS-130	50 (3.44)	43	704	1550

† TESTED AT 2250 PSI.

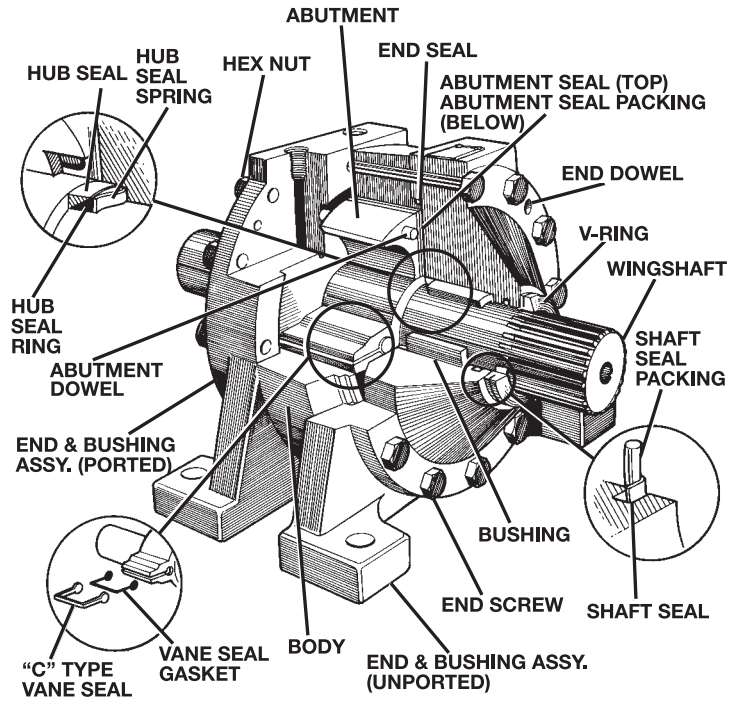
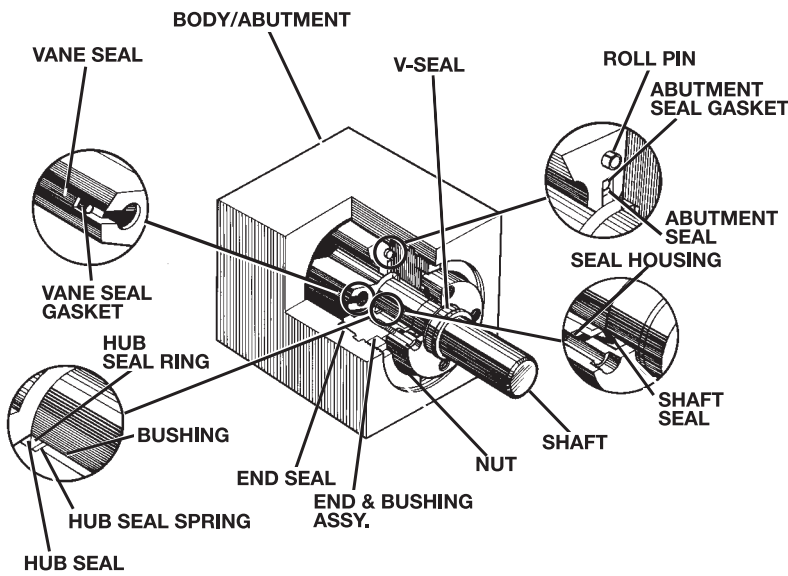

HOW TO ORDER

Please fill in ALL blocks in accordance with the KEY numbers and letters shown below.

Block #
1 2 3 4 5 6 7 8

Block 1 (STYLE)

SS Solid Shaft
 PP Special

Block 2 (SIZE)

*0.2A
 *0.5A
 1
 4
 8
 12
 25
 40
 65
 130

Block 3 (NO. OF VANES)

1V Single vane
 2V Double vane

Block 4 (MOUNTING)

E End
 F Foot
 B Base
 Z Special

Block 5 (SEALS)

B Buna "N" Standard shaft seal
 V Viton Standard shaft seal
 E Ethylene propylene
 X Two piece end—Viton shaft seal buna seals
 Y Two piece end—Viton shaft seal viton seals
 Z Special

Block 6 (SHAFT CONFIGURATION)

A Standard (Involute spline & plain for SS)
 B Plain end cut off
 C Plain both ends
 D Plain one end—Single key other end
 E Plain one end—Double key other end
 F Plain end cut off—Single key other end
 G Plain end cut off—Double key other end
 H Single key both ends
 J Double key both ends
 K Spline one end—Single key other end
 L Spline one end—Double key other end
 N Splined both ends
 Z Special

Block 7 (SHAFT MODIFICATION)

A Standard (None)
 B Drill, tap drive end of shaft
 C Drill, tap both ends of shaft
 ***D Potentiometer shaft hole opp drive end
 E Drill & tap end opposite drive end
 Z Special

Block 8 (PORTING)

1 N.P.T.
 2 SAE Straight threads standard
 3 Double N.P.T. ports
 4 Double SAE ports
 ** 5 Front ports—N.P.T.
 ** 6 Front ports—SAE
 7 Manifold ports (See manifold porting data for explanation)
 8 Body ports—N.P.T.
 9 Double manifold ports
 0 BSPP straight threads
 Z Special

* For Aluminum units an A is added to the key
 Example: SS-.05A-1V is an Aluminum Actuator
 SS-4-1V is a Cast Iron Actuator

** "Front ports" for end ported SS Series means adjacent to keyed or spline shaft end.

*** See Page 52 for size.



Micromatic

HIGH PRESSURE - HOLLOW SHAFT

6 Standard Sizes

3,000 PSI

Up to 57,000 in/lbs of Torque

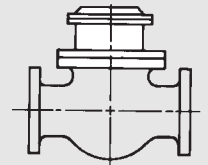
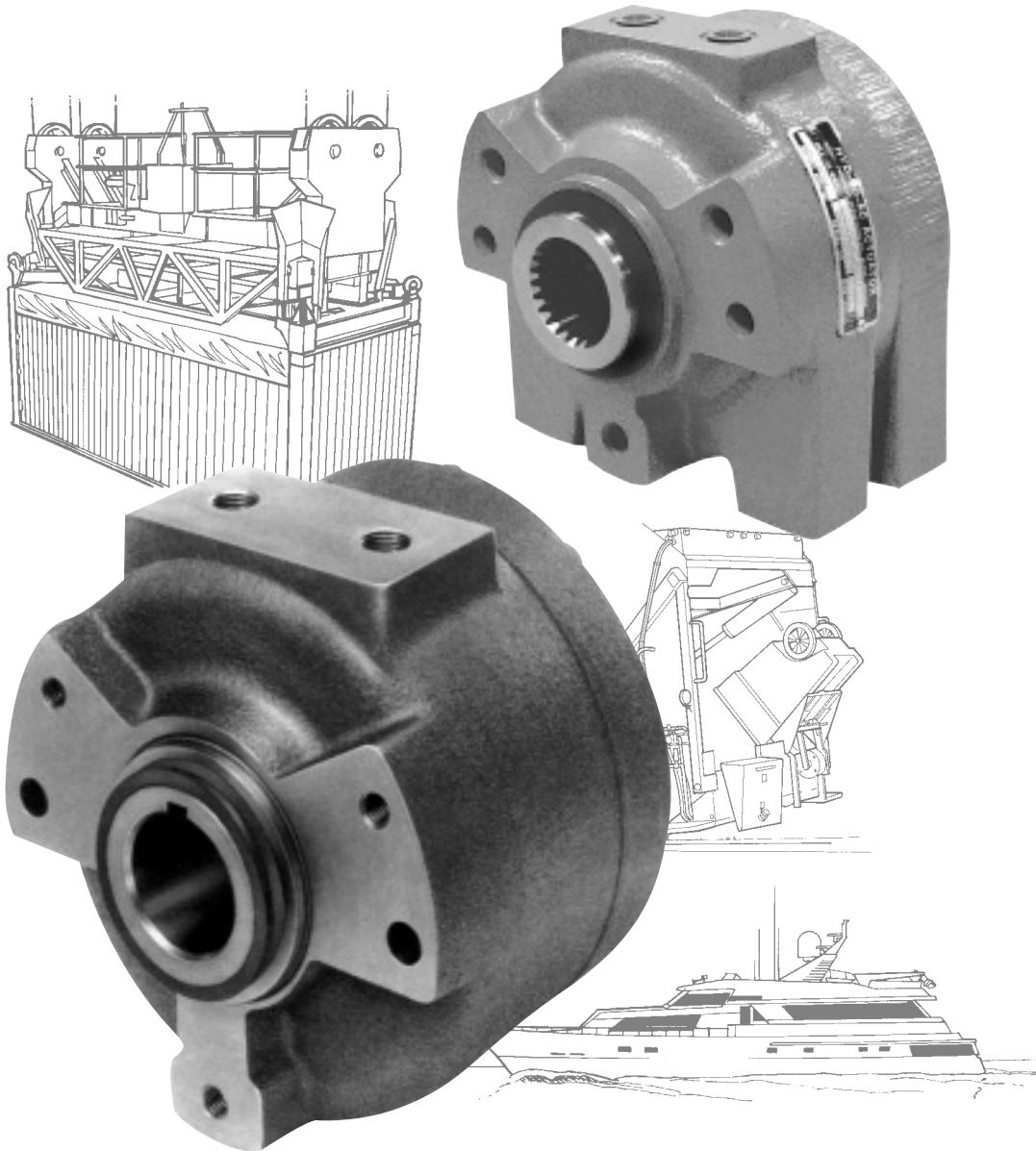

VALVE OPEN—CLOSE

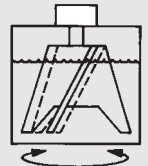

MIX—STIR

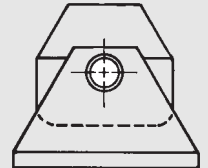

TURNOVER—DUMP

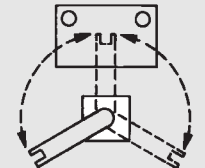

LOAD—POSITION—UNLOAD

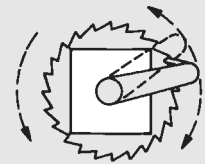

CONTINUOUS ROTATION



TURN—OSCILLATE

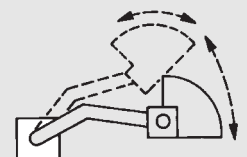

MATERIAL HANDLING

PROVIDING the “MUSCLE” for your lifting, turning, indexing, opening, closing, clamping, mixing, bending, testing, steering . . . **applications.**

HS MODELS

END MOUNTING HIGH PRESSURE 3000 PSI *1

SINGLE VANE HS-1.5, HS-2.5, HS-4

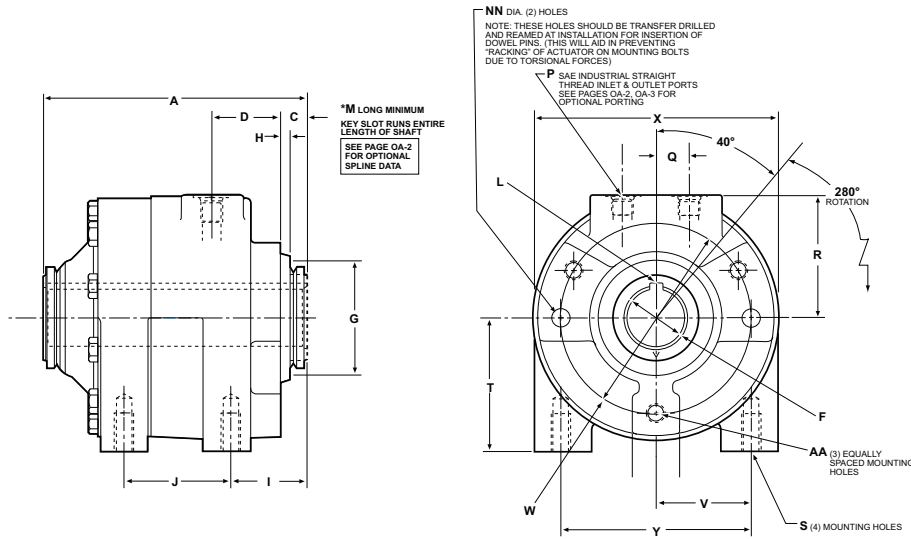

SINGLE VANE HS-6, HS-10, HS-15

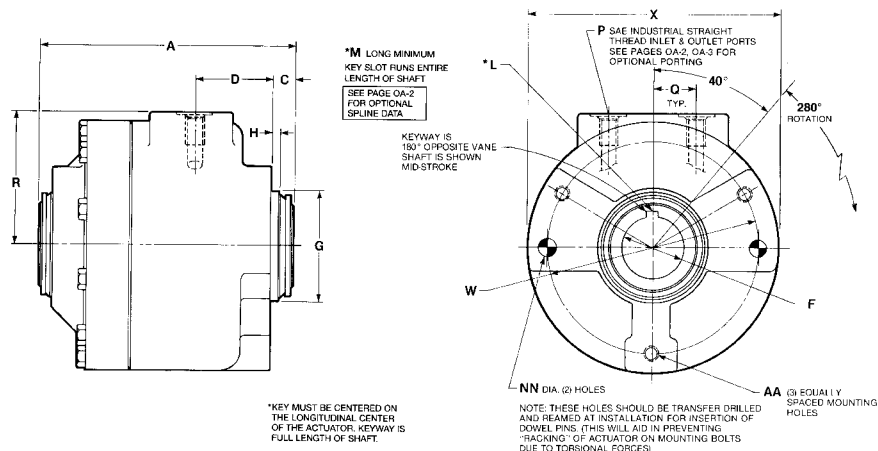

DOUBLE VANE

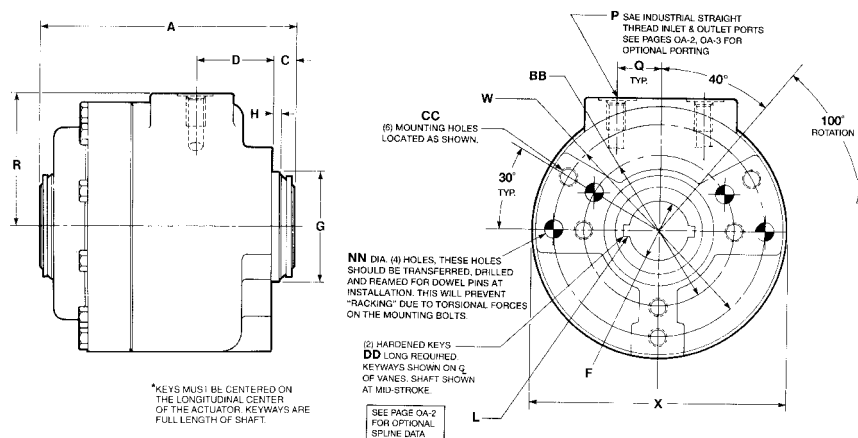

NOTE: See cut away view of 1V model on page 46.

NOTE: See pages 55 for optional manifold.

*1 2000 PSI maximum is recommended for severe duty applications, such as operating at maximum torque at high cycle rates for extended periods. Please consult factory for applications beyond 2000 PSI. 3000 PSI can be used on intermittent shockless actuations.

APPLICATION DATA DIMENSIONS IN INCHES (METRIC)

	HS-1.5	HS-2.5	HS-4	HS-6	HS-10	HS-15
A	6.12 (155.45)	6.92 (175.77)	8.12 (206.25)	7.25 (184.15)	8.25 (209.55)	9.97 (253.24)
C	.69 (17.53)	.69 (17.53)	.69 (17.53)	.69 (17.53)	.69 (17.53)	.69 (17.53)
D	1.81 (45.97)	1.81 (45.97)	1.81 (45.97)	2.50 (63.50)	2.50 (63.50)	2.50 (63.50)
① F	1.5020 (38.151)	1.5020 (38.151)	1.5020 (38.151)	2.0025 (50.864)	2.0025 (50.864)	2.0025 (50.864)
② G	2.9990 (76.175)	2.9990 (76.175)	2.9990 (76.175)	3.6240 (92.050)	3.6240 (92.050)	3.6240 (92.050)
⑤ H	.25 (6.35)	.25 (6.35)	.25 (6.35)	.25 (6.35)	.25 (6.35)	.25 (6.35)
I	2.00 (50.8)	2.00 (50.8)	2.00 (50.8)			
J	2.00 (50.8)	2.80 (71.12)	4.00 (101.6)			
③ L	$\frac{5}{16} \times \frac{5}{32}$ (7.94 x 3.96)	$\frac{5}{16} \times \frac{5}{32}$ (7.94 x 3.96)	$\frac{5}{16} \times \frac{5}{32}$ (7.94 x 3.96)	$\frac{3}{8} \times \frac{3}{16}$ (9.53 x 4.76)	$\frac{3}{8} \times \frac{3}{16}$ (9.53 x 4.76)	$\frac{3}{8} \times \frac{3}{16}$ (9.53 x 4.76)
M	1.38 (35.03)	2.25 (57.15)	3.50 (88.90)	3.00 (76.2)	4.50 (114.30)	7.00 (177.80)
④ P	$\frac{9}{16}$ -18 (22.352)	$\frac{9}{16}$ -18 (22.352)	$\frac{9}{16}$ -18 (22.352)	$\frac{3}{4}$ -16 (36.50)	$\frac{3}{4}$ -16 (36.50)	$\frac{3}{4}$ -16 (36.50)
Q	.88 (22.352)	.88 (22.352)	.88 (22.352)	1.437 (36.50)	1.437 (36.50)	1.437 (36.50)
R	3.22 (81.79)	3.22 (81.79)	3.22 (81.79)	4.44 (112.78)	4.44 (112.78)	4.44 (112.78)
S	$\frac{1}{2}$ -13 1.00 DP	$\frac{1}{2}$ -13 1.00 DP	$\frac{1}{2}$ -13 1.00 DP			
T	3.50 (88.9)	3.50 (88.9)	3.50 (88.9)			
V	2.50 (63.5)	2.50 (63.5)	2.50 (63.5)			
W	5.00 (127.00)	5.00 (127.00)	5.00 (127.00)	7.00 (177.80)	7.00 (177.80)	7.00 (177.80)
X	6.25 (158.75)	6.25 (158.75)	6.25 (158.75)	8.50 (215.90)	8.50 (215.90)	8.50 (215.90)
④ Y	5.00 (127.00)	5.00 (127.00)	5.00 (127.00)			
AA	$\frac{1}{2}$ -13 1.00 DP	$\frac{1}{2}$ -13 1.00 DP	$\frac{1}{2}$ -13 1.00 DP	$\frac{1}{2}$ -13 1.00 DP	$\frac{1}{2}$ -13 1.00 DP	$\frac{1}{2}$ -13 1.00 DP
BB	— (25.4)	— (25.4)	— (25.4)	5.00 (127.0)	5.00 (127.0)	5.00 (127.0)
CC	—	—	—	$\frac{5}{8}$ -11 1.13 DP	$\frac{5}{8}$ -11 1.13 DP	$\frac{5}{8}$ -11 1.13 DP
DD	—	—	—	7.25 (184.15)	8.25 (209.55)	9.97 (253.24)
NN	.468 (11.89) 1.25 DP (31.75)	.468 (11.89) 1.25 DP (31.75)	.468 (11.89) 1.25 DP (31.75)	.593 (15.06) 1.25 DP (31.75)	.593 (15.06) 1.25 DP (31.75)	.593 (15.06) 1.25 DP (31.75)

- ① TOLERANCE ± .001 (0.0254) HS-1.5, 2.5, 4
± .0015 (0.038) HS-6, 10, 15
- ② TOLERANCE ± .001 (0.0254)
- ③ SEE PAGE OA-2 FOR OPTIONAL SPLINE DATA
- ④ SEE PAGES OA-2, OA-3 FOR OPTIONAL PORT DATA
- ⑤ TOLERANCE ± .001

NOTE: See how to order on page 46.

PERFORMANCE

SINGLE VANE 280° ROTATION (±5°)						
MODEL	TORQUE IN-LBS (N•m)			VOLUMETRIC DISPLACEMENT IN ³ (cm ³)		APPROX. WEIGHT LB (Kg)
	1000 PSI (69.0 BAR)	2000 PSI (137.9 BAR)	3000 PSI (206.9 BAR)	PER 280°	PER RAD	
	HS-1.5	1350 (152.55)	2700 (305.10)	4050 (457.65)	7.30 (119.64)	
HS-2.5	2250 (254.25)	4500 (508.50)	6750 (762.75)	12.20 (199.95)	2.50 (40.97)	34 (15.42)
HS-4	3600 (406.80)	7200 (813.60)	10800 (1220.40)	19.54 (320.26)	4.00 (65.56)	41 (18.59)
HS-6	5720 (646.36)	11440 (1292.72)	17160 (1939.08)	31.05 (508.90)	6.36 (104.24)	58 (26.30)
HS-10	8600 (971.80)	17200 (1943.60)	25800 (2915.40)	46.59 (763.61)	9.54 (156.36)	67 (30.39)
HS-15	13500 (1525.50)	27000 (3051.00)	40500 (4576.50)	73.27 (1200.89)	15.00 (245.85)	83 (37.64)

DOUBLE VANE 100° ROTATION (±5°)						
MODEL	TORQUE IN-LBS (N•m)			VOLUMETRIC DISPLACEMENT IN ³ (cm ³)		APPROX. WEIGHT LB (Kg)
	1000 PSI (69.0 BAR)	2000 PSI (137.9 BAR)	3000 PSI (206.9 BAR)	PER 100°	PER RAD	
	HS-1.5			NA		
HS-2.5			NA			
HS-4			NA			
HS-6	12080 (1365.04)	24170 (2731.21)	36250 (4096.25)	22.20 (363.86)	12.72 (208.48)	68 (30.84)
HS-10	18120 (2047.56)	36250 (4096.25)	54370 (6143.81)	33.29 (545.62)	19.08 (312.72)	76 (34.47)
HS-15	28500 (3220.50)	57000 (6441.00)	NA	52.70 (863.75)	30.02 (492.03)	95 (43.08)

TEST PARAMETERS — OIL			
MODEL	MAX BREAK IN PSI (BAR)	BY-PASS LEAKAGE-MAX ALLOWABLE	
		CUBIC IN. PER MIN. AT 3000 PSI (206.9 BAR)	CUBIC CM. PER MIN. AT 3000 PSI (206.9 BAR)
HS-1.5	80 (5.52)	5	82
HS-2.5	80 (5.52)	6	98
HS-4	80 (5.52)	7	115
HS-6	50 (3.44)	8	131
HS-10	50 (3.44)	9	148
HS-15	50 (3.44)	10	164

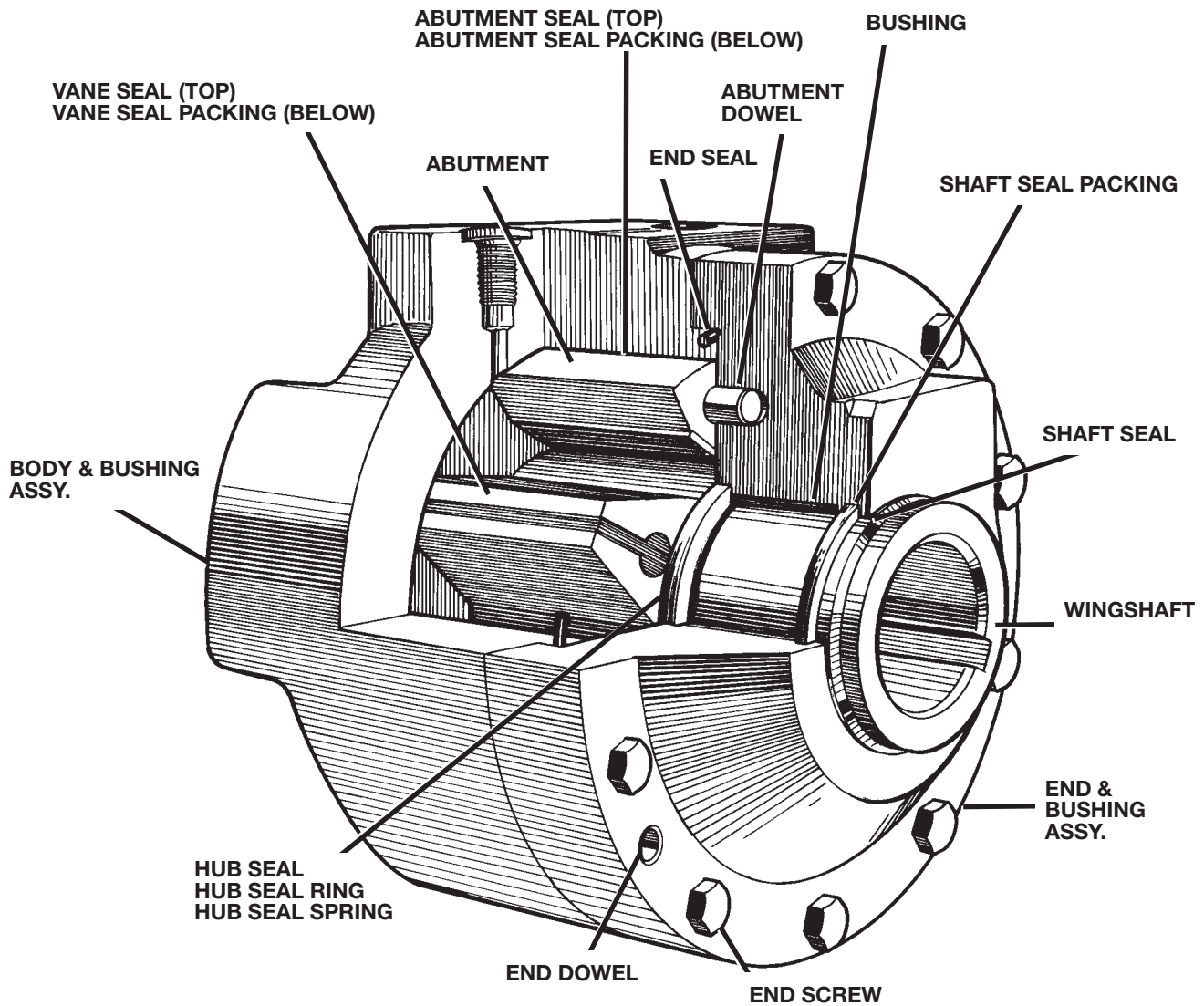

HOW TO ORDER

Please fill in ALL blocks in accordance with the KEY numbers and letters shown below.

Block #

1 2 3 4 5 6 7 8

Block 1 (STYLE)

HS Hollow shaft

Block 2 (SIZE)

1½

2½

4

6

10

15

Block 3 (NO. OF VANES)

1V Single vane

2V Double vane

Block 4 (MOUNTING)

E End

B Base (Available in sizes 1-1/2, 2-1/2 & 4 only.)

Block 5 (SEALS)

B Buna "N" Standard shaft seal

V Viton Standard shaft seal

E Ethylene propylene

Z Special

Block 6 (SHAFT CONFIGURATION)

A Standard (Internal key for HS)

M Internal spline (HS)

Z Special

Block 7 (SHAFT MODIFICATION)

A Standard (None)

Z Special

Block 8 (PORTING)

1 N.P.T.

2 SAE Straight threads standard

** 5 End ports—N.P.T.

** 6 End ports—SAE

7 Manifold ports (See manifold porting data for explanation)

0 BSPP straight threads

Z Special

** "End ports" for HS Series means on non-mounting end, parallel to shaft.

Not available on 2V units.



Micromatic

8 Standard Sizes

1,000 PSI

Up to 43,150 in/lbs of Torque

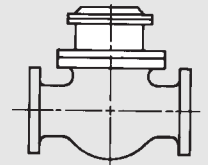
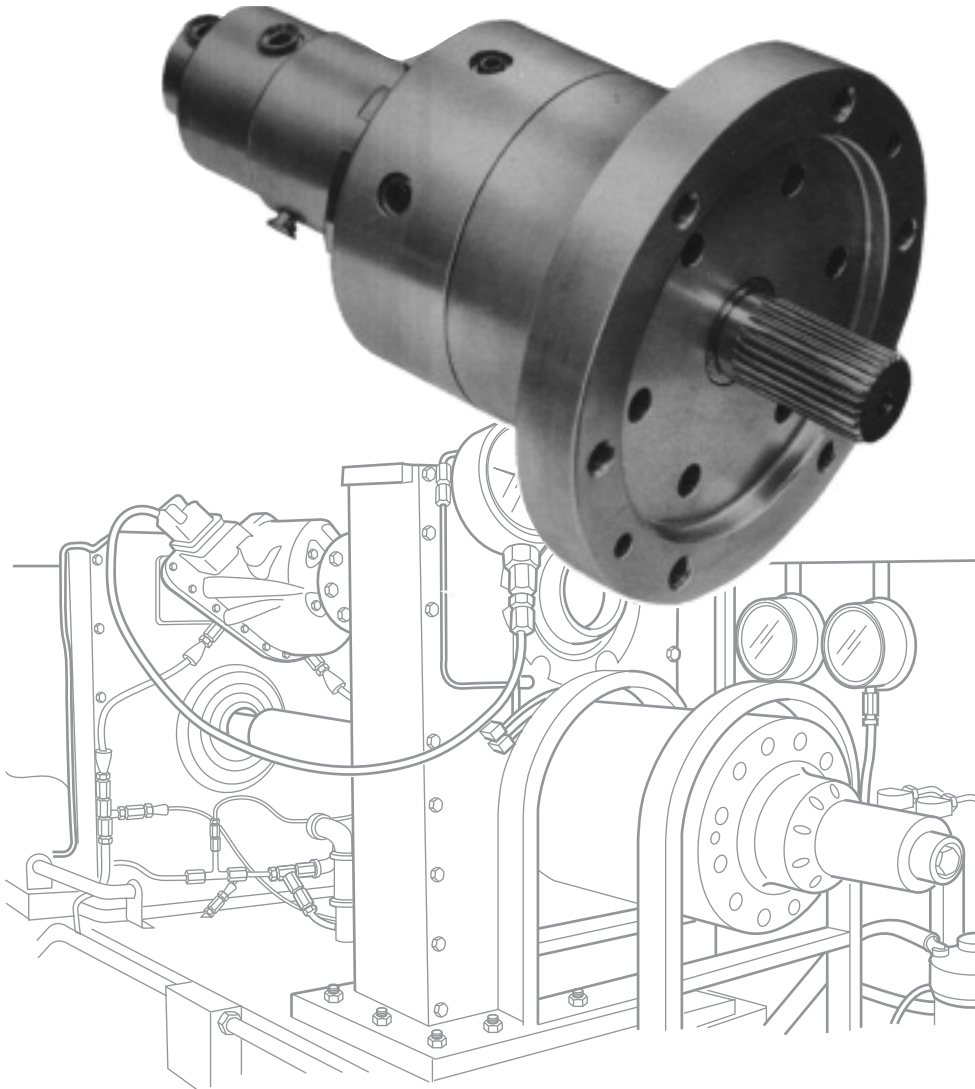

VALVE OPEN—CLOSE

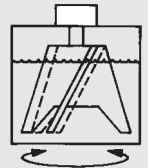

MIX—STIR

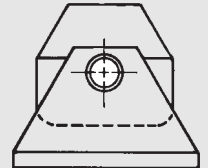

TURNOVER—DUMP

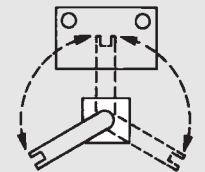

LOAD—POSITION—UNLOAD

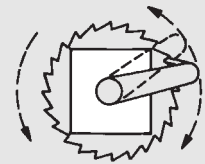

CONTINUOUS ROTATION



TURN—OSCILLATE

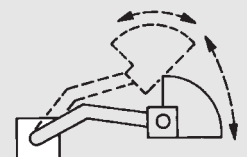

MATERIAL HANDLING

PROVIDING the “MUSCLE” for your clamping, twisting, testing. . . **applications.**

ROTATING ACTUATORS

The Rotating actuator is a new innovation of reciprocating torque actuators. Its interior design and construction are similar to standard lines of stationary actuators, but the Rotating actuator, unlike the stationary models, revolves in application. Also, its applications are entirely different.

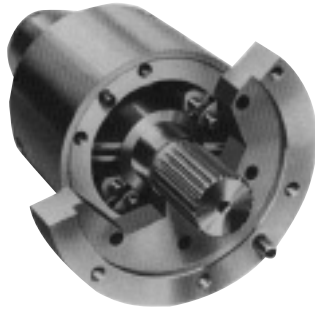

It consists of an aluminum alloy body with a precision machined cylindrical chamber, a central splined-end shaft on which vanes are fixed, and barriers or shoes that provide positive internal stops for the vanes. The number of vanes and shoes within the unit limit the arc of vane travel and effect the torque output capacities.

Power is derived from either hydraulic or pneumatic pressure directed against the vanes which, in turn, rotate the splined shaft. Although the shoes limit the movement of the vanes to a precise maximum degree, any required arc of movement can be controlled by valves and external positive stops. Infinitely variable, increasing and decreasing, and sudden loads can be applied.

Reciprocating torque actuators, like most power outputs, are usually mounted to a stationary base. But the Rotating actuator revolves in application as an integral part of a functioning device: the body, vanes, and shaft rotate in unison, maintaining their relationship until fluid pressure changes the position of the vanes.

APPLICATIONS

DRAWING A. Centrifugal, bending, and torque testing of couplings, fatigue specimens, and universal joints is done in this typical arrangement. The Rotating Rotac actuator supplies the torque load, stress, or shock the items.

DRAWING B. Two automotive differentials are tested in this arrangement. The Rotating Rotac actuator's reciprocal capabilities impose continuous forward, reverse and variable action plus shock loading on the specimens.

DRAWING C. In chucking lathe applications, the Rotating Rotac actuator actuates the jaws of the chuck, and shifts the locations of the work for eccentric turning during the machining cycle.

DRAWING D. In a gear testing arrangement, an electric motor drives the entire assembly, including the Rotating Rotac actuator. Hydraulic power input to the Rotac actuator imposes load or shock to the gear train.

It Works Like This:

In applications such as machining, the Rotating actuator is mounted to the spindle and rotates at the same speed. When fluid pressure is applied, it either advances or reverses the relative position of the vanes — therefore the shaft — to supply the necessary movement, or torque, as the job requires. In test and fatigue applications, the Rotating actuator is mounted remote of the power source but as an integral unit of entire driving assembly. Its function is to impose torque circulating within the driven assembly but independent of the rotating power source. Controlled fluid

pressure on the vanes within the actuator apply load, or shock as the test may require, on the driven specimens.

In applications and illustrations shown in this brochure, the Rotating actuator is equipped with a hydraulic union for pressure input. Similar devices can be used to accommodate pneumatic pressure.

Rotating actuators are designed in “small” and “medium” models with two and three vanes to provide torque outputs for many applications. The following drawings, specifications lists, and charts will help to pinpoint the exact model to suit a given purpose. In addition to this information engineering service is available through your field representative, or through the factory for application assistance and special designs.

Engineering Data

Standard rotating actuators use Deublin Rotating Hyd. Deu-Plex unions with special features

Max. R.P.M. — 5,000 @ 750 PSI Max.

Max. Air Pressure 150 PSI

NOTE: Lubricated air is required for pneumatic operation.

NOTE: Splined couplings are available.

NOTE: Unless otherwise specified, units are dynamically balanced per ISO 1940 G 2.5 from diameters indicated with ▲

TORQUE RATINGS IN INCH-POUNDS P.S.I.

Model	100	200	400	500	600	750
SS-2V	400	850	1,700	2,100	2,550	3,100
SS-3V	600	1,350	2,650	3,300	3,950	4,900
SL-2V	850	1,700	3,400	4,200	5,000	6,250
SL-3V	1,300	2,650	5,300	6,600	7,900	9,850
MS-2V	2,000	3,550	7,500	9,250	11,000	13,600
MS-3V	3,000	6,000	11,500	14,500	17,500	21,550
ML-2V	3,750	7,500	15,000	18,500	22,000	27,650
ML-3V	6,000	12,000	23,500	29,500	35,000	43,150

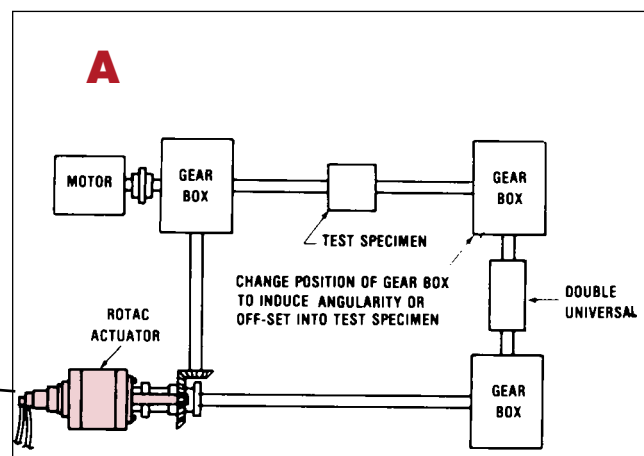

NOTE: See cut away view on page 50.

ROTATING ACTUATORS SMALL

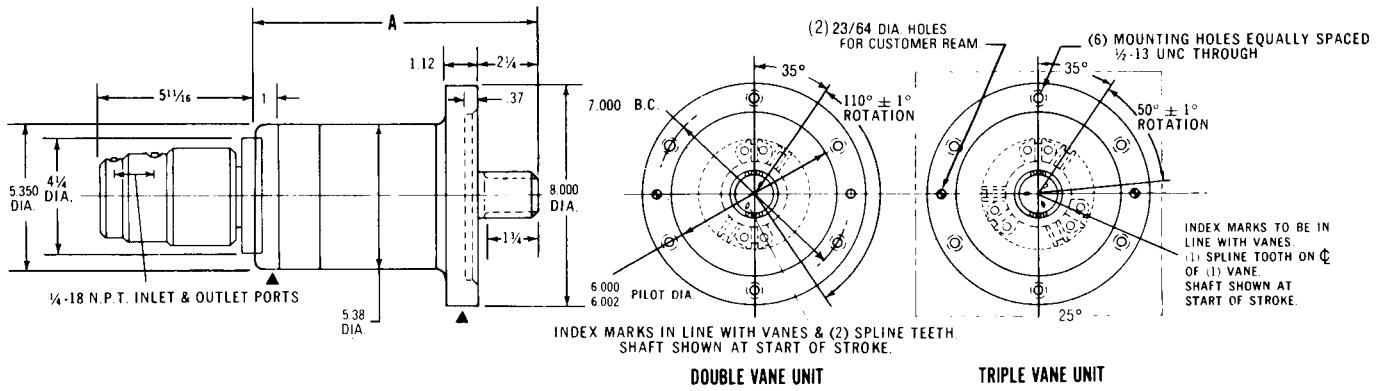

Spline Data:

STD. S.A.E. External Flat Root.
Side Fit Involute Splines
Class 1 Fit Per S.A.E. J498b — 1969
26 Teeth — 20/40 Pitch — P.A. 30°
1.3360/1.3310 Major Dia.
1.3000 Pitch Dia. (Ref.)

NOTE: Uses 26R-2 Couplings
Ref. Couplings page 56

Model	Internal Size	Displacement Per Stroke	Displacement Per Radian	Rotation Of Vane	Est. Weight	A
SS-2V	3.75 x 2	8.64 cu. in.	4.50 cu. in.	110°	26.9 lb.	8 1/4
SS-3V	3.75 x 2	5.89 cu. in.	6.75 cu. in.	50°	27.1 lb.	10 1/4
SL-2V	3.75 x 4	17.28 cu. in.	9.00 cu. in.	110°	32.1 lb.	
SL-3V	3.75 x 4	11.78 cu. in.	13.50 cu. in.	50°	32.5 lb.	

Model	Break-Away in PSI	OIL				Break-Away in PSI	AIR			
		Leakage Cubic in. Per Min. at 1000 psi		Leakage Cubic cm. Per Min. at 1000 psi			Leakage Cubic ft. Per Min. at 100 psi		Leakage Cubic cm. Per Min. at 100 psi	
		2V	3V	2V	3V		2V	3V	2V	3V
SS	30	3.0	3.5	49.2	57.4	20	25	30	7080	8496
SL	30	3.2	3.7	52.5	60.6	20	25	30	7080	8496

ROTATING ACTUATORS MEDIUM

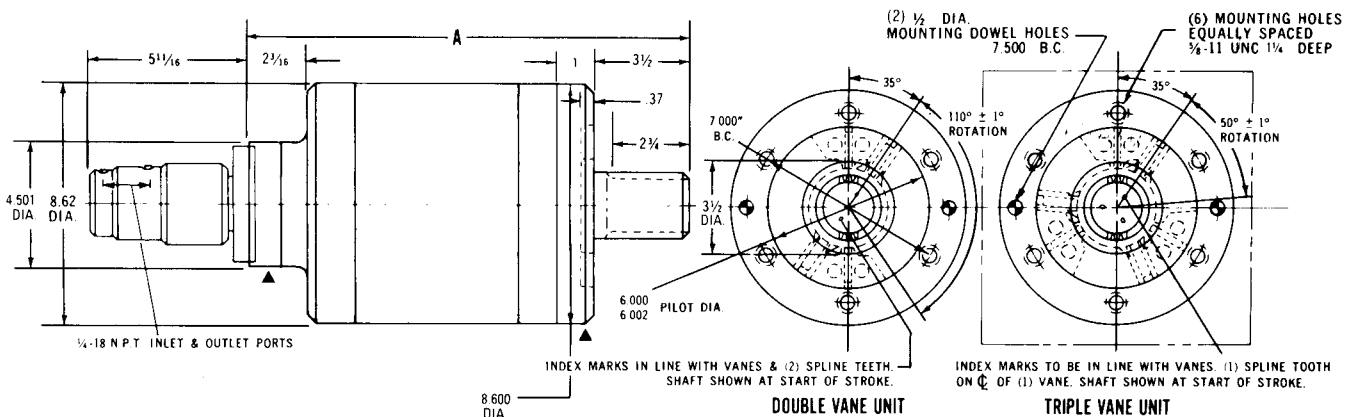

Spline Data:

STD. S.A.E. External Flat Root.
Side Fit Involute Splines
Class 1 Fit Per S.A.E. J498b — 1969
26 Teeth — 12/24 Pitch — P.A. 30°
2.2293/2.2243 Major Dia.
2.1667 Pitch Dia. (Ref.)

NOTE: Uses 26R-10 Couplings
Ref. Couplings page 56

Model	Internal Size	Displacement Per Stroke	Displacement Per Radian	Rotation Of Vane	Est. Weight	A
MS-2V	6 x 3	38.9 cu. in.	20.26 cu. in.	110°	72 Lb	10 3/16
MS-3V	6 x 3	26.5 cu. in.	30.37 cu. in.	50°	76 Lb	16 3/16
ML-2V	6 x 6	77.8 cu. in.	40.53 cu. in.	110°	98 Lb	
ML-3V	6 x 6	53 cu. in.	60.74 cu. in.	50°	104 Lb	

Model	Break-Away in PSI	OIL				Break-Away in PSI	AIR			
		Leakage Cubic in. Per Min. at 1000 psi		Leakage Cubic cm. Per Min. at 1000 psi			Leakage Cubic ft. Per Min. at 100 psi		Leakage Cubic cm. Per Min. at 100 psi	
		2V	3V	2V	3V		2V	3V	2V	3V
MS	30	5.6	6.4	91.8	104.9	20	25	30	7080	8496
ML	30	5.8	6.6	95.1	108.2	20	30	35	8496	9912

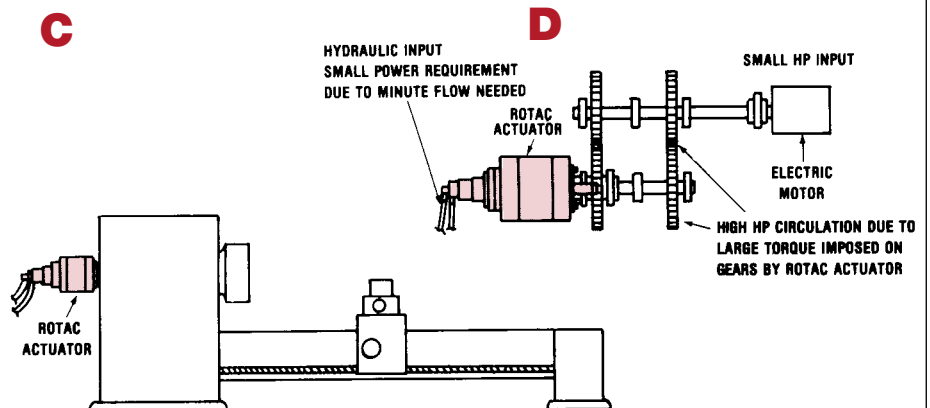
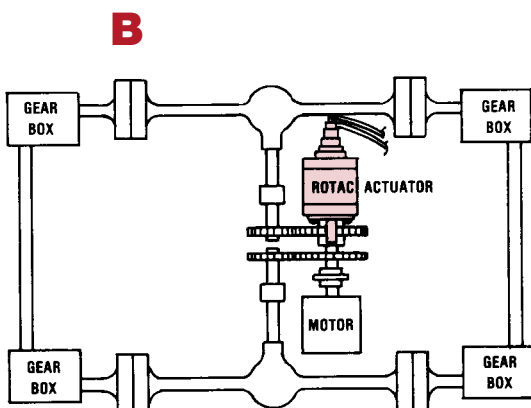

NOTE: See How to Order on page 50.

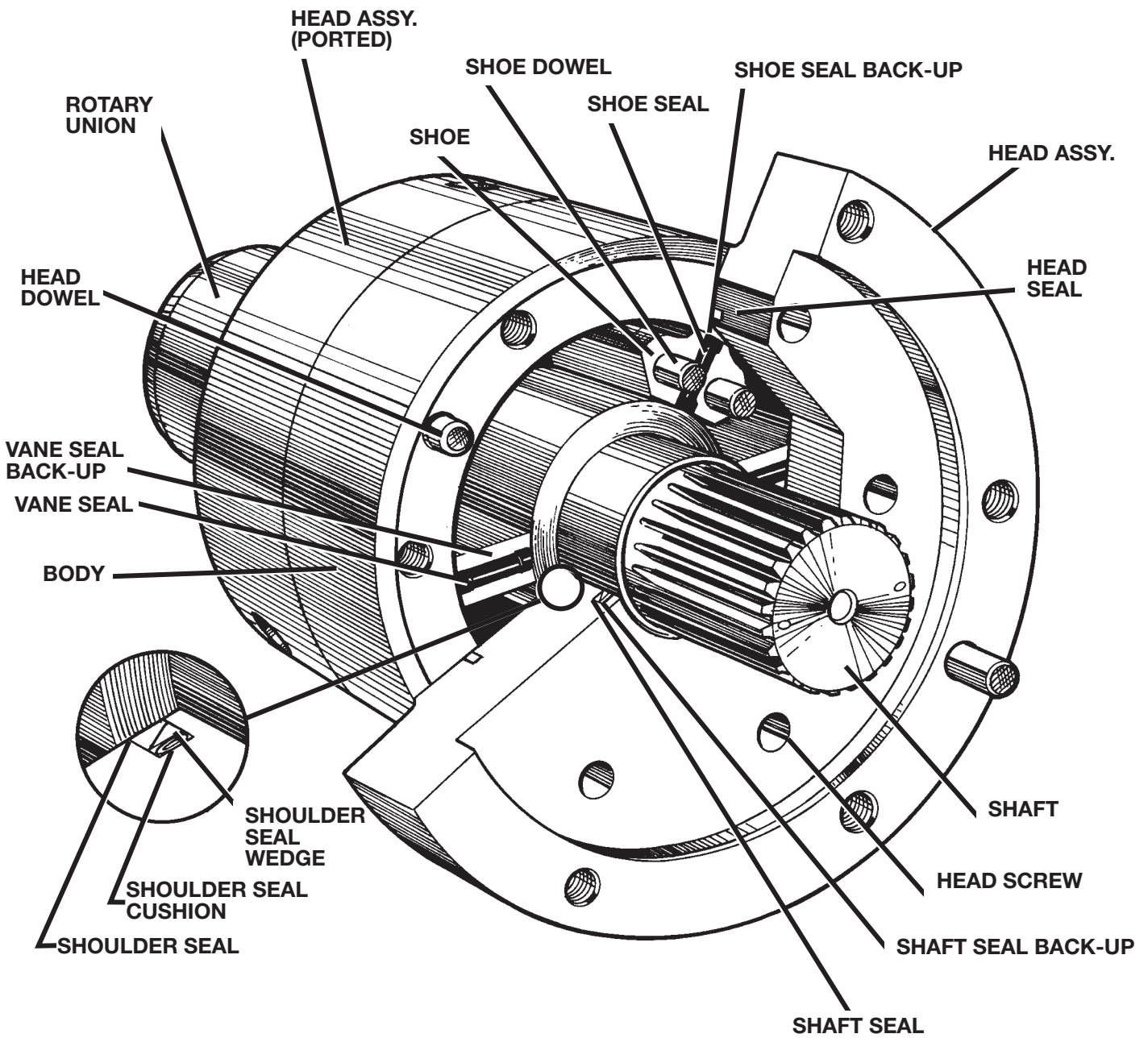

HOW TO ORDER

Sample: **MS 2V SE IS END OIL**

Model _____

SS, SL, MS, ML

Number of Vanes _____

2V—Double Vane
3V—Triple Vane

Shaft Extension _____

SE—Single Extension

_____ **Fluid Medium**

Oil, Air, Other

_____ **Mounting**

End, Flange, Special

_____ **Shaft Type**

IS—30° Involute Spline
Z—Special

If you require a special shaft extension, special mounting, or other special requirements, please enclose a drawing showing these requirements.



Micromatic

Options & Accessories

FOR ROTARY ACTUATORS

OPTIONS:

- Optional Threaded Porting
- Shaft End Potentiometer Shaft Holes
- Shaft End Tapped Holes
- Manifold Porting
- Keyway Data

ACCESSORIES:

- Cross Port Relief Manifolds
- Couplings

PROVIDING the “**MUSCLE**” for your lifting, turning, indexing, opening, closing, clamping, mixing, bending, testing, steering. . . **applications.**

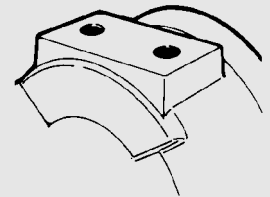

PAGE 55

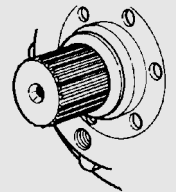

PAGE 55

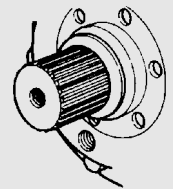

PAGE 55

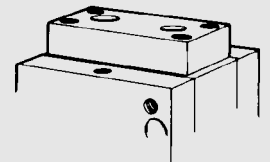

PAGE 56

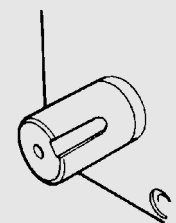

PAGE 57

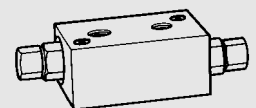

PAGE 58

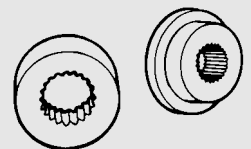

PAGE 59

SPECIAL OPTIONS

OPTIONAL THREADED PORTING, SHAFT END POTENTIOMETER SHAFT HOLES, AND SHAFT END TAPPED HOLES

Model Description	National Pipe Thread (NPT)		BSP		Potentiometer Shaft Hole	Shaft End Tapped Hole
	Size	Threads Per Inch	Size	Thread		

HS Series (Hollow Shaft)

HS-1 1/2 HS-2 1/2 HS-4	1/4	18	3/8	3/8-19 BSPP	N.A.	N.A.
HS-6 HS-10 HS-15	1/2	14	1/2	1/2-14 BSPP	N.A.	N.A.

SS Series (Solid Shaft)

SS-1	1/8	27	1/8	1/8-28 BSPP	$\frac{.2486}{.2491} \times .50$ DP	5/16-18 UNC x 1/2 DP
SS-4	1/4	18	1/4	1/4-19 BSPP	$\frac{.2486}{.2491} \times .50$ DP	3/8-16 UNC x 9/16 DP
SS-8 SS-12 HA-36	3/8	18	3/8	3/8-19 BSPP	$\frac{.2486}{.2491} \times .50$ DP	1/2-13 UNC x 3/4 DP
SS-25	1/2	14	1/2	1/2-14 BSPP	$\frac{.2486}{.2491} \times .50$ DP	3/4-10 UNC x 1-1/8 DP
SS-40	1	11-1/2	3/4	3/4-14 BSPP	$\frac{.2486}{.2491} \times .50$ DP	3/4-10 UNC x 1-1/8 DP
SS-65 SS-130	1	11-1/2	1	1-11 BSPP	$\frac{.2486}{.2491} \times .50$ DP	1-8 UNC x 1-1/2 DP*

SS Aluminum (Solid Shaft)

SS-0.2A SS-0.5A	N/A		N/A	N/A	.186-.187 x .38 DP	10-32 UNF-2B x .38 DP
	1/8	27	1/8	1/8-28 BSPP		
SS-1A	1/8	27	1/8	1/8-28 BSPP	$\frac{.2486}{.2491} \times .50$ DP	5/16-18 UNC x 1/2 DP
SS-4A	1/4	18	1/4	1/4-19 BSPP	$\frac{.2486}{.2491} \times .50$ DP	3/8-16 UNC x 9/16 DP
SS-8A	3/8	18	3/8	3/8-19 BSPP	$\frac{.2486}{.2491} \times .50$ DP	1/2-13 UNC x 3/4 DP

* 1/2-13 UNC x 1 DP tapped holes provided as standard for lifting.

MP Series (Solid Shaft)

MP-11	1/8	27	CONSULT FACTORY			
MP-22	1/4	18				
MP-32 MP-34	3/8	18				
MP-63	3/4	14				
MP-84	3/4	14				
MP-105	1	11-1/2				
MP-116 MP-128	1-1/4	11-1/2				

OPTIONAL SPLINE DATA FOR HOLLOW SHAFT SERIES

HS Series (Hollow Shaft)

New Model Description	Pitch	Teeth	Pressure Angle	Major Dia.	Minor Dia.	Pitch Dia.	Length	Spline Std.
HS-1 1/2 HS-2 1/2 HS-4	16/32	24	30°	$\frac{1.5735}{1.5625}$	$\frac{1.4375}{1.4425}$	1.5000	1.75	ASA B5.15-1960
HS-6 HS-10 HS-15	12/24	26	30°	$\frac{2.2630}{2.2500}$	$\frac{2.0833}{2.0883}$	2.1667	2.00	ASA B5.15-1960

NOTE: Models HS-1 1/2, 2 1/2, and 4 have index mark at 6 o'clock.
Models HS-6, -10 and -15 have index mark at 6 o'clock

SPECIAL OPTIONS (CONTINUED)

MANIFOLD PORTING

Hollow Shaft Series

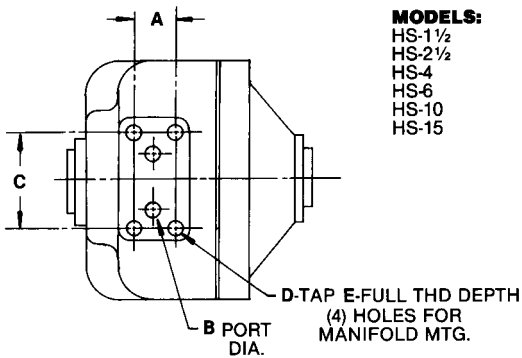

Solid Shaft Series

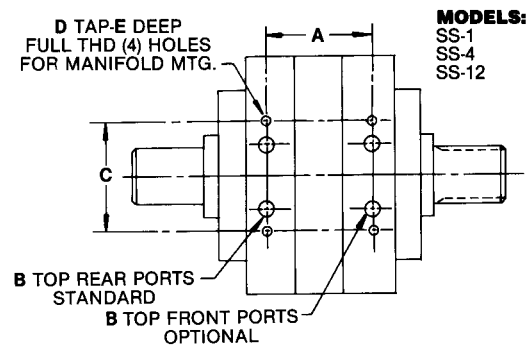

Solid Shaft Series

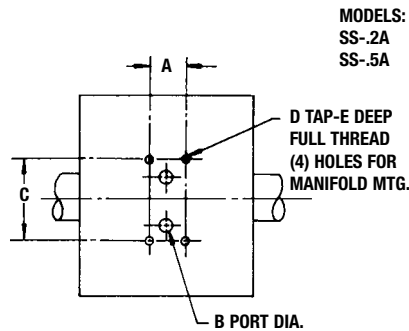

Solid Shaft Series

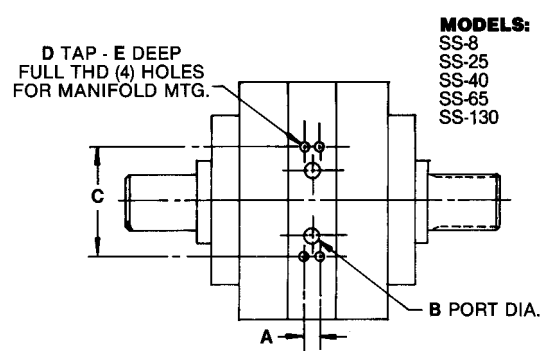

NOTE: Port locations are symmetrical to manifold mtg. holes.
NOTE: See actuator catalog pages for port location and spacing.

Model Description	A	B	C	D	E
-------------------	---	---	---	---	---

HS Series (Hollow Shaft)

HS-1½ HS-2½ HS-4	1.000	1/4	2-3/4"	14-20 UNC	1/2"
HS-6	1.375	7/16	3-3/8"	3/8-16 UNC	3/4"
HS-10 HS-15	1.750	7/16	4"	1/2-13 UNC	1"

SS Series (Solid Shaft)

SS-0.2A	1.086	1/8	1-5/8"	#8-32 UNC	1/4"
SS-0.5A	1.250	5/32	1-3/4"	#10-32 UNF	3/8"
SS-1	1.848	5/32	2"	1/4-20 UNC	3/8"
SS-4	3.000	1/4	3"	1/4-20 UNC	1/2"
SS-8	1.125	1/2	3-1/4"	5/16-18 UNC	11/16"
SS-12	4.000	5/16	4"	3/8-16 UNC	5/8"
SS-25	1.875	11/16	4-7/8"	1/2-13 UNC	1-1/8"
SS-40	2.000	7/8	6"	1/2-13 UNC	1"
SS-65	3.000	1-5/32	6-1/2"	5/8-11 UNC	1"
SS-130	2.750	1-5/32	8-1/4"	5/8-11 UNC	1"

SPECIAL OPTIONS (CONTINUED)

OPTIONAL SHAFT KEYWAY DATA

Keyway Drives are recommended only for low pressure and low cycle applications. Note the maximum recommended torque for each model in the table below.

Max. recommended torque values are based on using a key with a min. yield strength of 65,000 psi and operating the unit within normal accepted application guidelines.

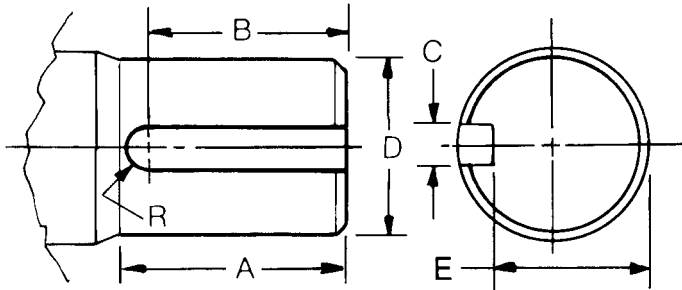

SS SERIES:

STANDARD KEYWAY IS LOCATED AT 12 O'CLOCK, 6 O'CLOCK ON MODELS .2A & .5A WHEN WINGSHAFT IS AT MID-POSITION OF TRAVEL

Model Description	Shaft Ext. (A)	Keyway Length (B) ± .02	Keyway Width (C) + .0005 - .0015	Shaft Dia. (D)	Keyway Depth (E)	Max.* Recommended Torque (in. lb) (One Key)	Max. Supply Pressure
SS Series (Solid Shaft)							
SS-1-1V SS-1-2V	1.07	.750	.250	1.0360 1.0350	.905 .910	1,620	1,350 (1V) 675 (2V)
SS-4-1V SS-4-2V	1.83	1.250	.375	1.5460 1.5445	1.353 1.358	6,040	1,585 (1V) 793 (2V)
SS-8-1V	2.28	1.875	.500	1.9370 1.9355	1.681 1.686	15,140	1,892 (1V)
SS-12-1V SS-12-2V	2.63	2.000	.500	2.1970 2.1955	1.941 1.946	18,320	1,472 (1V) 736 (2V)
SS-25-1V	4.11	3.250	.750	3.000 2.998	2.625 2.620	60,975	2,448 (1V)
HA-36-1V	3.86	3.250	.750	2.8460 2.8410	2.461 2.471	57,780	1,605 (1V)
SS-40-1V SS-40-2V	4.11	3.250	.750	3.3460 3.3430	2.963 2.968	67,990	1,700 (1V) 850 (2V)
SS-65-1V SS-65-2V	4.54	3.875	1.000	3.846 3.841	3.341 3.345	124,190	1,910 (1V) 955 (2V)
SS-130-1V SS-130-2V	6.66	5.500	1.250	5.2960 5.2920	4.667 4.662	303,520	2,335 (1V) 1,167 (2V)
SS Aluminum (Solid Shaft)							
SS-0.2A-1V	1.11	.750	.1240 .1253	.594/.593	.530 .525	460	2,305 (1V)
SS-0.5A-1V SS-0.5A-2V	1.46	.700	.1875	.715/.714	.616/.621	780	1,738 (1V) 868 (2V)
SS-1A-1V SS-1A-2V	1.07	.750	.250	1.0360 1.0350	.905 .910	1,620	1,350 (1V) 675 (2V)
SS-4A-1V SS-4A-2V	1.83	1.250	.375	1.5460 1.5445	1.353 1.358	6,040	1,585 (1V) 793 (2V)
SS-8A-1V	2.28	1.875	.500	1.9370 1.9355	1.681 1.686	15,140	1,892 (1V)

*NOTE: For double key use (1.75) times this value up to full torque capacity of actuator.

ACCESSORIES

CROSS-PORT RELIEF MANIFOLD DATA

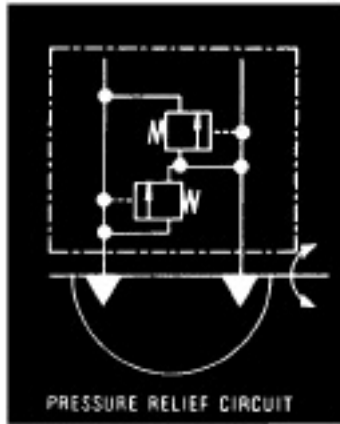

SPECIFICATIONS
 TYPE — PISTON DIFFERENTIAL
 CAPACITY — 40 G.P.M.
 PRESSURE RANGE —
 COMPATIBLE WITH
 MODEL MP
 FACTORY SET AT 50 P.S.I.
 ABOVE MAX.
 PRESSURE RATING

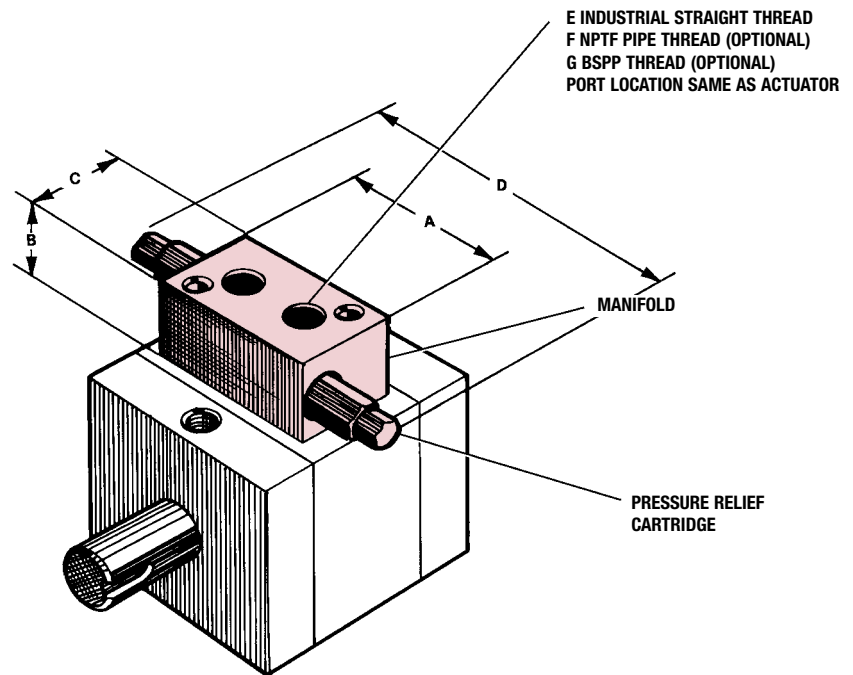

Model	Ass'y No. St. Thd.	Opt. Ass'y No. Pipe Thd.	A	B	C	D	E (2)* St. Thd.	F (1)* NPTF	G (0)* BSPP
SS-1	401498-00*	—	3.00	2.50	4.00	7.62	$\frac{7}{16}$ -20	$\frac{1}{8}$ -27	$\frac{1}{8}$ -28
SS-4	411552-00*	—	4.00	2.50	4.25	8.25	$\frac{9}{16}$ -18	$\frac{1}{4}$ -18	$\frac{3}{8}$ -19
SS-8	416061-00*	—	4.25	2.50	4.87	8.75	$\frac{9}{16}$ -18	$\frac{3}{8}$ -18	$\frac{3}{8}$ -19
SS-12	421669-00*	—	5.00	3.00	5.38	9.00	$\frac{3}{4}$ -16	$\frac{3}{8}$ -18	$\frac{3}{8}$ -19
SS-25	452451-00*	—	6.38	2.50	6.25	10.05	$\frac{7}{8}$ -14	$\frac{1}{2}$ -14	$\frac{1}{2}$ -14
SS-40	431491-00*	—	7.38	2.50	6.25	11.00	$1\frac{5}{16}$ -12	1-11 $\frac{1}{2}$	$\frac{3}{4}$ -14
SS-65	436046-00*	—	8.50	2.50	5.00	10.75	$1\frac{5}{16}$ -12	1-11 $\frac{1}{2}$	1-11
SS-130	441238-00*	—	10.25	2.50	5.00	12.00	$1\frac{5}{8}$ -12	1-11 $\frac{1}{2}$	1-11
HS-1.5, 2.5, 4.0	511040-00*	—	3.75	2.50	2.50	8.25	$\frac{9}{16}$ -18	$\frac{1}{4}$ -18	$\frac{3}{8}$ -19
HS-6.0	452458-00*	—	4.50	2.50	3.50	9.50	$\frac{3}{4}$ -16	$\frac{1}{2}$ -14	$\frac{1}{2}$ -14
HS-10.0, 15.0	452456-00*	—	5.50	2.50	3.00	9.38	$\frac{3}{4}$ -16	$\frac{1}{2}$ -14	$\frac{1}{2}$ -14
MP-32, 34	26-11-218	26-11-200	4.00	2.50	2.50	8.38	$\frac{7}{8}$ -14	$\frac{1}{2}$ -14	—
MP-63	26-11-219	26-11-201	5.00	2.50	3.00	9.05	$1\frac{1}{16}$ -12	$\frac{3}{4}$ -14	—
MP-84	26-11-220	26-11-202	6.00	2.50	4.00	9.75	$1\frac{5}{16}$ -12	1-11 $\frac{1}{2}$	—
MP-105	26-11-221	26-11-203	7.00	2.50	4.00	10.44	$1\frac{5}{8}$ -12	1 $\frac{1}{4}$ -11 $\frac{1}{2}$	—
MP-116 & 128	26-11-222	26-11-205	8.00	2.50	5.00	11.56	$1\frac{7}{8}$ -12	1 $\frac{1}{2}$ -11 $\frac{1}{2}$	—

All Dimensions in Inches

ACCESSORIES (CONTINUED)

COUPLINGS (See actuator model sections for SAE, ASA spline specifications.)

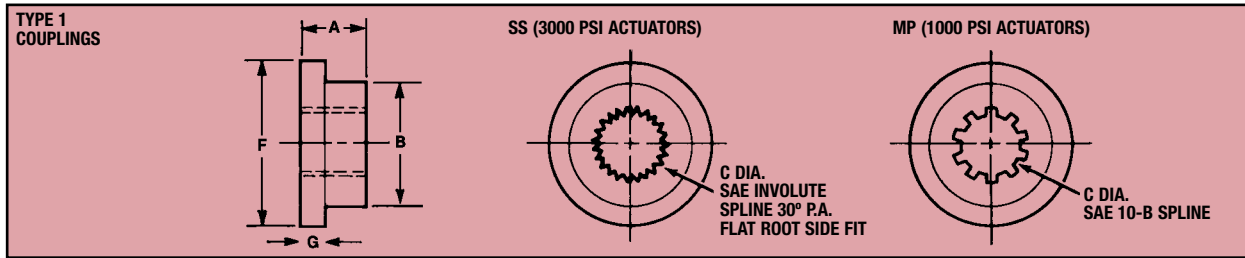

	Part No.	Model	A	B	C	F	G
For "SS" Models	451498-001	SS-1	1.00	1.75	20T-20/40P-1.0000P.D.	3.50	0.50
	451498-002	SS-4	1.50	2.50	24T-16/32P-1.5000P.D.	5.25	0.62
	451498-008	SS-8	2.00	3.00	30T-16/32P-1.8750P.D.	6.00	0.75
	451498-003	SS-12	2.25	3.50	26T-12/24P-2.1667P.D.	7.00	0.75
	451498-004	SS-40	3.50	5.00	26T-8/16P-3.2500P.D.	10.50	1.00
	451498-006	SS-65	3.88	6.00	30T-8/16P-3.7500P.D.	12.00	1.38
For "MP" Models	451498-005	SS-130	5.50	8.00	31T-6/12P-5.1667P.D.	16.00	1.38
	26-11-241	MP-11	0.50	0.88	* 19T-40/80P-0.4570P.D.	2.00	0.25
	26-11-240	MP-22	0.75	1.12	* 29T-40/80P-0.7250P.D.	2.25	0.31
	26-11-176	MP-32	1.63	2.31	1.25	3.75	0.50
		MP-34					
	26-11-177	MP-63	1.75	3.63	2.00	5.25	0.63
	26-11-178	MP-84	2.13	4.13	2.50	6.00	0.75
	26-11-179	MP-105	2.50	5.25	3.00	7.25	0.88
For "26R" Models	26-11-180	MP-116	3.00	6.25	3.50	8.50	1.00
	26-11-181	MP-128	4.25	7.25	4.00	10.00	1.25
	26-11-5034	26R-2	1.63	2.31	26T-20/40P-1.3000P.D.	3.75	0.50
	26-11-5035	26R-5	1.75	3.63	26T-16/32P-1.6250P.D.	5.25	0.63
	26-11-5036	26R-10	2.13	4.13	26T-12/24P-2.1667P.D.	6.00	0.75
	26-11-5037	26R-17	2.50	5.25	26T-10/20P-2.6000P.D.	7.25	0.88
	26-11-5038	26R-31	3.00	6.25	32T-10/20P-3.2000P.D.	8.50	1.00
	26-11-5039	26R-62	4.25	7.25	32T-8/16P-4.0000P.D.	10.00	1.25
	26R-124	5.25	8.75	38T-8/16P-4.7500P.D.	12.25	1.75	

*Involute Serration

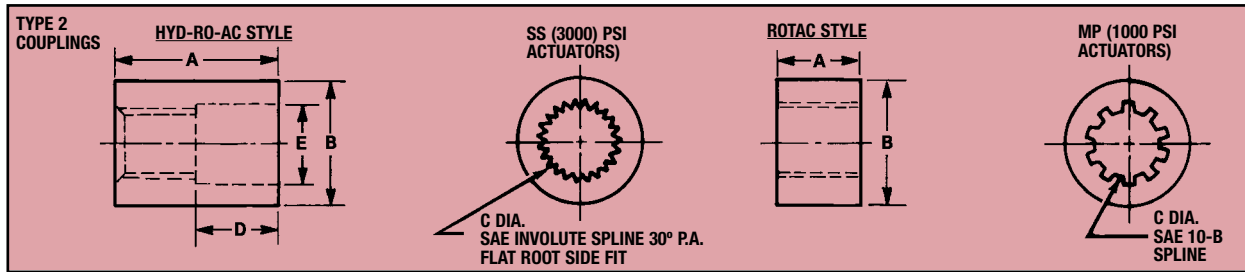

	Part No.	Model	A	B	C	D	E
For "SS" Models	451497-010	SS-2A	1.75	1.00	18T-32/64P-0.5625P.D.	0.88	0.626
	451497-009	SS-.5A	2.00	1.25	22T-32/64P-0.6875P.D.	1.00	0.751
	451497-001	SS-1	2.00	1.75	20T-20/40P-1.0000P.D.	1.00	1.126
	451497-002	SS-4	3.00	2.50	24T-16/32P-1.5000P.D.	1.50	1.751
	451497-008	SS-8	4.00	3.00	30T-16/32P-1.8750P.D.	2.00	2.126
	451497-003	SS-12	4.50	3.50	26T-12/24P-2.1667P.D.	2.25	2.501
	451497-004	SS-40	6.00	5.00	26T-8/16P-3.2500P.D.	3.50	3.751
	451497-006	SS-65	8.00	6.00	30T-8/16P-3.7500P.D.	3.88	4.376
451497-005	SS-130	10.00	8.00	31T-6/12P-5.1667P.D.	5.50	6.001	
For "MP" Models	26-11-182	MP-32	1.63	2.00	1.25	—	—
		MP-34					
	26-11-183	MP-63	2.13	3.25	2.00	—	—
	26-11-184	MP-84	2.50	3.75	2.50	—	—
	26-11-185	MP-105	3.00	4.75	3.00	—	—
	26-11-186	MP-116	4.25	5.75	3.50	—	—
26-11-187	MP-128	4.25	5.75	4.00	—	—	
For "26R" Models	26-11-5041	26R-2	1.63	2.00	26T-20/40P-1.3000P.D.	—	—
	26-11-5042	26R-5	1.75	2.75	26T-16/32P-1.6250P.D.	—	—
	26-11-5043	26R-10	2.13	3.25	26T-12/24P-2.1667P.D.	—	—
	26-11-5044	26R-17	2.50	3.75	26T-10/20P-2.6000P.D.	—	—
	26-11-5045	26R-31	3.00	4.75	32T-10/20P-3.2000P.D.	—	—
	26-11-5046	26R-62	4.25	5.75	32T-8/16P-4.0000P.D.	—	—
	26-11-5047	26R-124	5.25	7.00	38T-8/16P-4.7500P.D.	—	—

***Visit us online at
www.rotachydroac.com
www.micromaticllc.com***

“In compliance with our policy of continuing product improvement, specifications and information contained in this catalog are subject to change.”



Micromatic

525 BERNE STREET • BERNE, INDIANA 46711
260/589-2136 • FAX 260/589-8966
www.rotachydroac.com • www.micromaticllc.com